



MANUFACTURED BY:
Backyard Discovery
3305 Airport Drive, Pittsburg, KS 66762
800-856-4445

Backyard Discovery Australia Pty Ltd 2/7 Hood Street, Hampton VIC 3188, Phone: 1800-087-941

GRAYSON PEAK Swing Set Model # 2400221

The assembly manual must be retained
since it contains important information



WARNING

Adult Assembly Required.

Not suitable for children under 36 months due to small parts.

FOR DOMESTIC USE ONLY. INTENDED FOR OUTDOOR USE.



Please visit www.backyarddiscovery.com

For the most up to date assembly manual, to register your set, or to order replacement parts

Para obtener instrucciones en español, visite www.backyarddiscovery.com



**EASY STEP-BY-STEP
3D INTERACTIVE INSTRUCTIONS**
DOWNLOAD THE FREE APP



Made in China

INS-2400221-A-GRAYSON PEAK-AUS 08-20-24

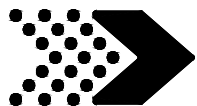

Place the set on level ground, not less than 6'-7" [2 m] from any structure or obstruction such as a fence, garage, house, overhanging branches, laundry lines, or electrical wires.

- While assembling unit, take time before and after each phase to make sure fort is level. If fort is not level, assembly will be difficult and improper assembly may result. Extra care must be taken to insure the fort is square.
- The safe play area refers to a zone extending 6'-7" (2m) beyond the play product on all sides, including the space above the play product.

SAFE PLAY AREA DIAGRAM

Ground Dimension

13' - 6 1/2" [4.1m] x 12' - 6 1/2" [3.8m]

Safe Play Area

25' - 8" [7.8m] x 26' - 8 1/2" [8.1m]

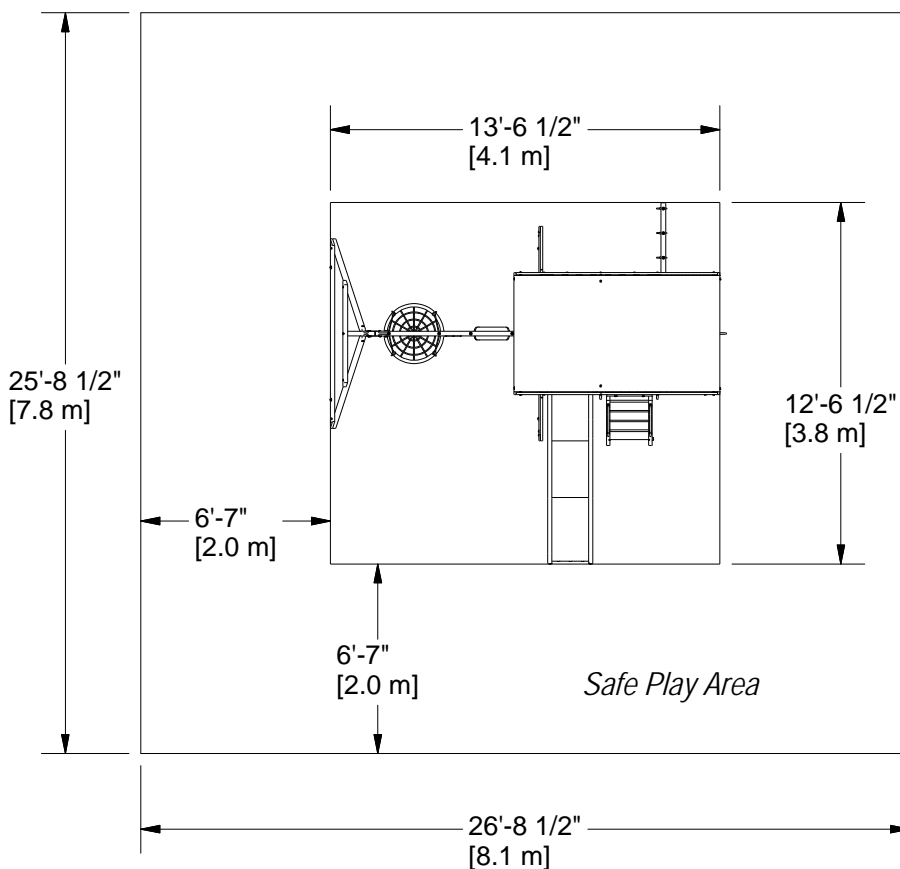

SAFE PLAY HEIGHT: 16'-6 1/2" [5.0 m]
MAXIMUM FALL HEIGHT: 6'-3 1/2" [1.9 m]

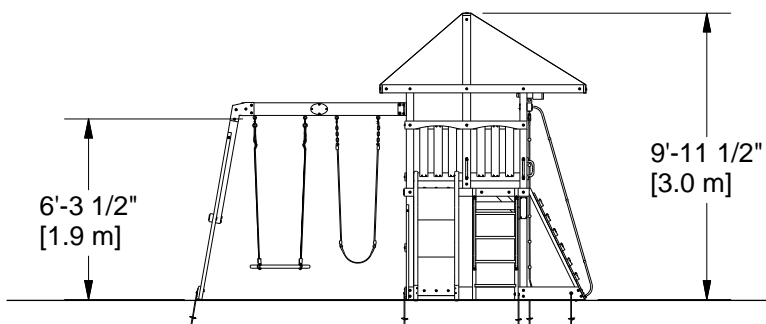

General Information:

Your set has been designed and engineered for children only and for residential use only.
 A maximum of 150 lbs. per child is recommended for play activities designed for individual use.
 A maximum of 120 lbs. per child is recommended for play activities designed for multiple child use.
 A maximum of 9 children is recommended for this swing set.



Wood Components (Not to Scale)



B2 | UPRIGHT POST - W4L13768
(x1) | 3"x3"x89 1/2" (76x76x2274)

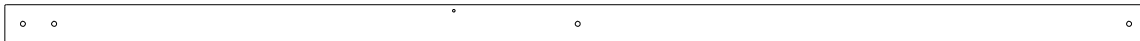

B3 | UPRIGHT POST - W4L13769
(x1) | 3"x3"x89 1/2" (76x76x2274)

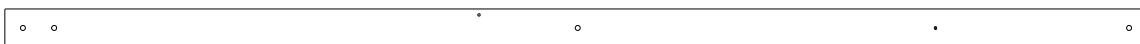

B4 | UPRIGHT POST - W4L13770
(x1) | 3"x3"x89 1/2" (76x76x2274)



E1 | RAIL - W4L13761
(x1) | 1 3/8"x3"x51 7/8" (36x76x1318)

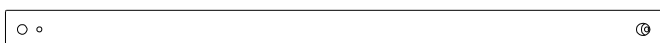

E2 | RAIL - W4L13755
(x1) | 1 3/8"x3"x51 7/8" (36x76x1318)

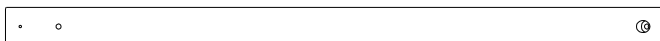

E3 | RAIL - W4L13762
(x1) | 1 3/8"x3"x51 7/8" (36x76x1318)



E74 | LEFT UPRIGHT - W4L13775
(x1) | 1 3/8"x3 3/8"x50 3/4" (36x86x1290)



E75 | RIGHT UPRIGHT - W4L13776
(x1) | 1 3/8"x3 3/8"x50 3/4" (36x86x1290)

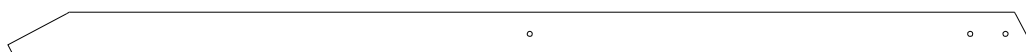

E77 | ANGLE BRACE - W4L13782
(x2) | 1 3/8"x3 3/8"x80 1/2" (36x86x2043)

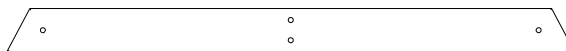

E79 | END SUPPORT - W4L13783
(x1) | 1 1/2"x3 1/2"x44 1/2" (36x86x1127)



G1 | GROUND BOARD - W4L13582
(x1) | 1"x5 1/4"x79 1/8" (24x134x2010)



G2 | WALL RAIL - W4L07153
(x1) | 1"x5 1/4"x48 7/8" (24x134x1243)



G50 | GROUND BOARD - W4L13784
(x1) | 1"x5 1/4"x79" (24x134x2006)



Wood Components (Not to Scale)



H1 | ANGLE BRACE - W4L07127
(x2) | 1"x3 3/8"x44 1/2" (24x86x1129)



H2 | FLOOR SUPPORT - W4L13772
(x1) | 1"x3 3/8"x52 1/8" (24x86x1324)

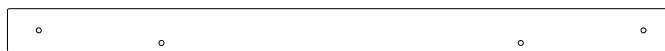

H3 | FLOOR SUPPORT - W4L13773
(x1) | 1"x3 3/8"x52 1/8" (24x86x1324)

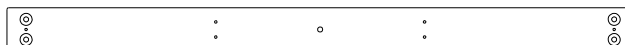

H4 | FLOOR SUPPORT - W4L07130
(x1) | 1"x3 3/8"x48 7/8" (24x86x1243)



H5 | FLOOR SUPPORT - W4L07131
(x1) | 1"x3 3/8"x48 7/8" (24x86x1243)

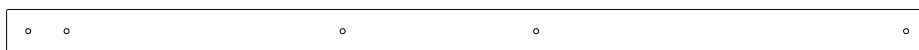

H6 | UPRIGHT - W4L13763
(x1) | 1"x3 3/8"x72" (24x86x1828)



H7 | UPRIGHT - W4L13764
(x1) | 1"x3 3/8"x72" (24x86x1828)

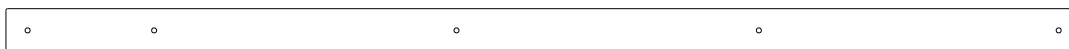

H8 | ROOF RAIL - W4L13765
(x2) | 1"x3 3/8"x83 7/8" (24x86x2132)



H9 | ROOF RAIL - W4L13766
(x2) | 1"x3 3/8"x50 7/8" (24x86x1291)



H10 | ROOF RAIL - W4L13767
(x1) | 1"x3 3/8"x48 7/8" (24x86x1243)

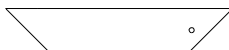

H11 | DECK BRACE - W4L07296
(x2) | 1"x3 3/8"x17 3/4" (24x86x450)



H12 | DECK BRACE - W4L13771
(x4) | 1"x3 3/8"x15 7/8" (24x86x402)

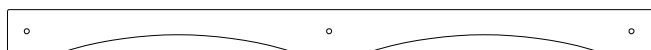

H13 | ARCHED RAIL - W4L13774
(x1) | 1"x3 3/8"x50 7/8" (24x86x1292)

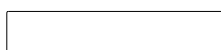

H81 | LADDER RUNG - W4L13778
(x4) | 1"x3 3/8"x17 1/8" (24x86x434)



Wood Components (Not to Scale)



J1 | FLOOR JOIST - W4L07139
(x2) | 1"x2 3/8"x50 1/4" (24x60x1275)



J2 | FLOOR SUPPORT - W4L06710
(x4) | 1"x2 3/8"x3" (24x60x76)



K1 | GROUND BOARD - W4L07122
(x1) | 5/8"x5 1/4"x74 1/4" (16x134x1888)



K2 | GROUND BOARD - W4L07123
(x1) | 5/8"x5 1/4"x89 3/8" (16x134x2270)



K3 | GROUND BOARD - W4L07124
(x1) | 5/8"x5 1/4"x50 1/8" (16x134x1274)

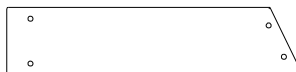

K4 | GROUND BOARD - W4L13756
(x1) | 5/8"x5 1/4"x23 1/8" (16x134x588)

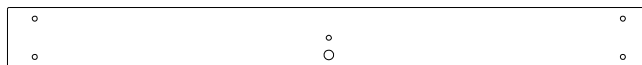

K5 | GROUND BOARD - W4L13757
(x1) | 5/8"x4 3/4"x50 1/4" (16x120x1275)

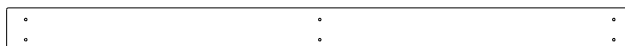

M1 | ROCK WALL BOARD - W4L13758
(x7) | 5/8"x3 3/8"x48 7/8" (16x86x1243)

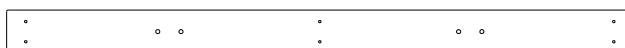

M2 | ROCK WALL BOARD - W4L13759
(x3) | 5/8"x3 3/8"x48 7/8" (16x86x1243)



M3 | ROCK WALL BOARD - W4L13760
(x3) | 5/8"x3 3/8"x48 7/8" (16x86x1243)

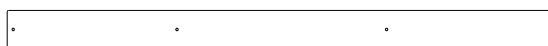

M4 | FLOOR BOARD - W4L07141
(x2) | 5/8"x3"x42 7/8" (16x76x1090)



M5 | FLOOR BOARD - W4L07142
(x1) | 5/8"x3 3/8"x48 7/8" (16x86x1242)



M8 | WALL RAIL - W4L07145
(x2) | 5/8"x3 3/8"x50 7/8" (16x86x1292)



Wood Components (Not to Scale)



M9 | WALL RAIL - W4L07146
(x3) 5/8"x3 3/8"x48 7/8" (16x86x1243)



M44 | PICKET - W4L07152
(x13) 5/8"x3 3/8"x21 3/8" (16x86x542)

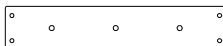

M77 | SLIDE BRACE - W4L08748
(x1) 5/8"x3 3/8"x17 1/4" (16x86x438)



M78 | CENTER SLIDE BRACE - W4L08749
(x2) 5/8"x3 3/8"x17 1/4" (16x86x438)



M102 | ATTACHMENT BOARD - W4L13779
(x1) 5/8"x3 3/8"x19" (16x86x482)



M103 | REAR SUPPORT - W4L13777
(x1) 5/8"x3 3/8"x19" (16x86x482)



SB74 | SWING BEAM 2 POSITION - W4L13780
(x1) 2"x5 1/4"x68 3/4" (50x134x1745)

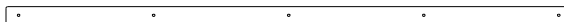

T1 | SUPPORT BOARD - W4L07140
(x2) 1"x1 3/8"x44 1/8" (24x34x1122)



W1 | SUPPORT BOARD - W4L07156
(x1) 2"x3 3/8"x78 7/8" (50x86x2005)



W71 | SWING BEAM SUPPORT - W4L13781
(x1) 2"x3 3/8"x49 3/8" (50x86x1254)

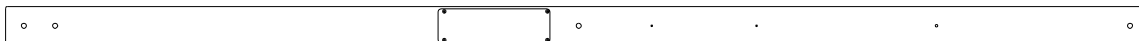

B1 | UPRIGHT POST ASSEMBLY - W2A02851
(x1) 3"x3"x89 1/2" (76x76x2274)

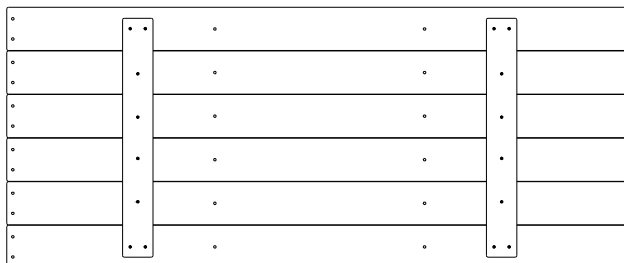

FP1 | FLOOR PANEL - W2A02850
(x2) 1 1/4"x20 3/8"x48 5/8" (32x519x1242)



Hardware Components

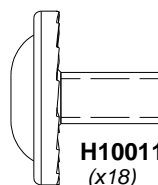

H100115 | BOLT WH
(x18) | 5/16x1/2

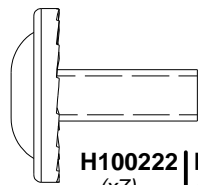

H100222 | BOLT WH
(x7) | 5/16x3/4

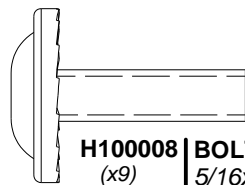

H100008 | BOLT WH
(x9) | 5/16x1

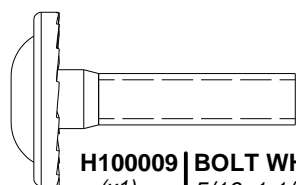

H100009 | BOLT WH
(x1) | 5/16x1 1/4

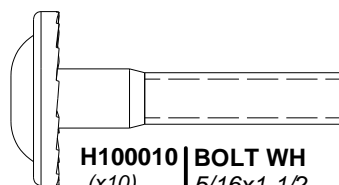

H100010 | BOLT WH
(x10) | 5/16x1-1/2

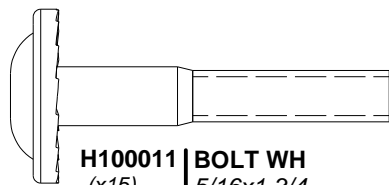

H100011 | BOLT WH
(x15) | 5/16x1 3/4

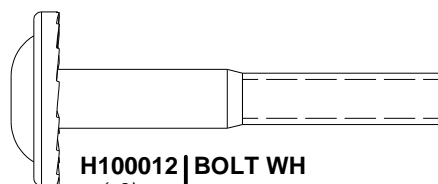

H100012 | BOLT WH
(x3) | 5/16x2

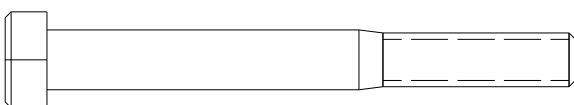

H100047 | BOLT HEX
(x2) | 5/16x2 3/4



H100505 | BOLT WH
(x7) | 5/16x4 3/4

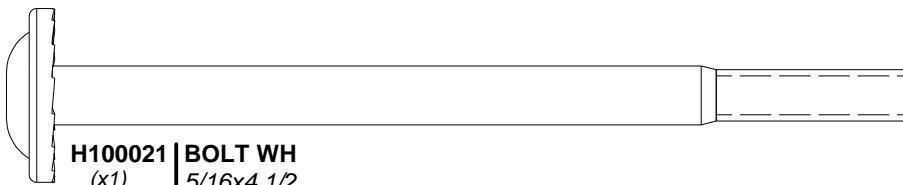

H100021 | BOLT WH
(x1) | 5/16x4 1/2

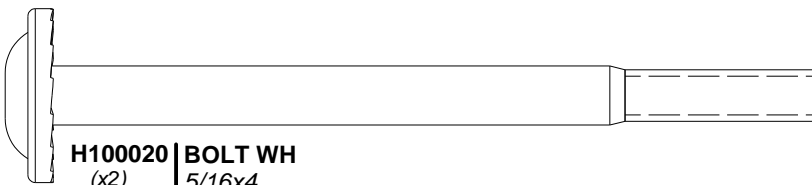

H100020 | BOLT WH
(x2) | 5/16x4

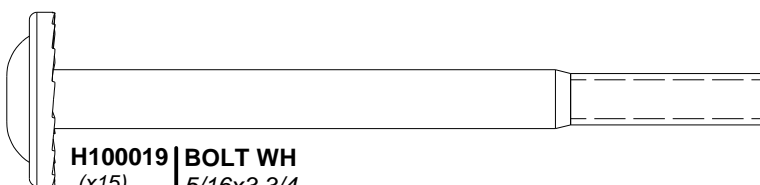

H100019 | BOLT WH
(x15) | 5/16x3 3/4



H100018 | BOLT WH
(x18) | 5/16x3 1/2

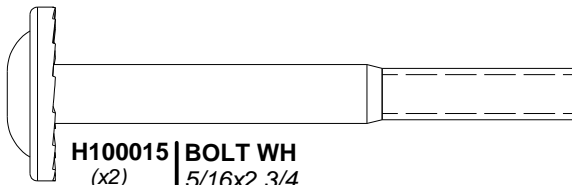

H100015 | BOLT WH
(x2) | 5/16x2 3/4

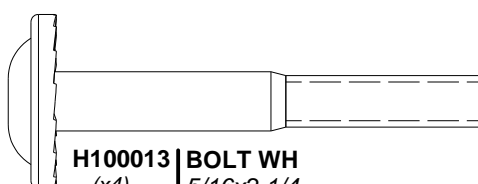

H100013 | BOLT WH
(x4) | 5/16x2 1/4

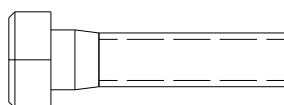

H100042 | BOLT HEX
(x4) | 5/16x1 1/4

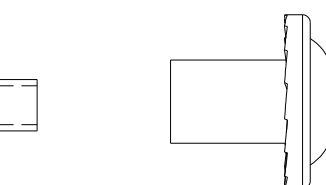

H100004 | NUT BARREL WH
(x9) | 5/16 x 5/8

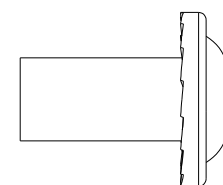

H100005 | NUT BARREL WH
(x17) | 5/16x7/8

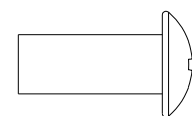

H100831 | NUT BARREL PTH BLK
(x4) | 1/4x3/4

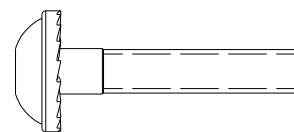

H100142 | BOLT WH
(x2) | 1/4x1-1/4



Hardware Components

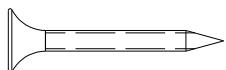

H100088 | SCREW PFH
(x56) | 8x1 1/8

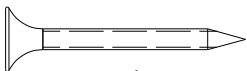

H100087 | SCREW PFH
(x2) | 8x1 1/4

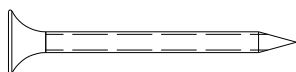

H100086 | SCREW PFH
(x176) | 8x1 1/2

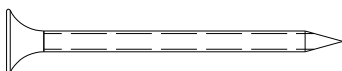

H100089 | SCREW PFH
(x19) | 8x1 3/4

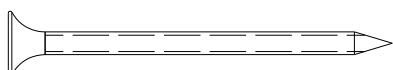

H100111 | SCREW PFH
(x17) | 8x2

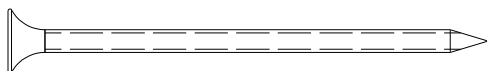

H100090 | SCREW PFH
(x35) | 8x2 1/2"

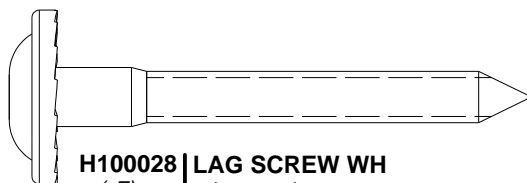

H100028 | LAG SCREW WH
(x7) | 5/16x2 1/2

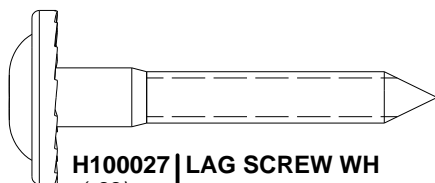

H100027 | LAG SCREW WH
(x22) | 5/16x2

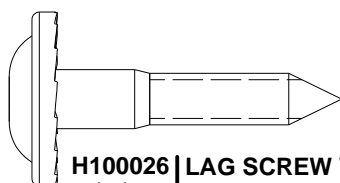

H100026 | LAG SCREW WH
(x2) | 5/16x1 1/2

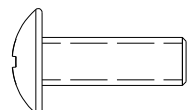

H100063 | BOLT PTH
(x20) | 1/4x3/4

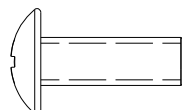

H100832 | BOLT PTH BLK (with LOCTITE)
(x4) | 1/4x3/4

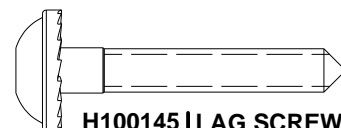

H100145 | LAG SCREW WH
(x7) | 1/4x1 1/2

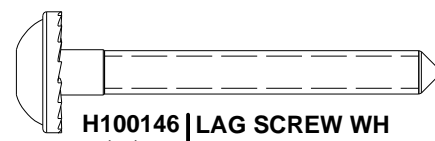

H100146 | LAG SCREW WH
(x9) | 1/4x2

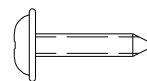

H100128 | SCREW PWH
(x2) | 8x5/8

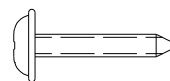

H100070 | SCREW PWH
(x19) | 8x3/4

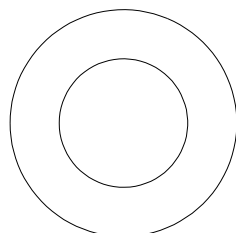

H100103 | WASHER SAFETY
(x8) | 17x30

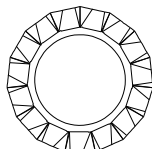

H100031 | WASHER LOCK EXT
(x19) | 12x19

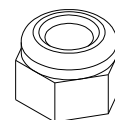

H100110 | NUT LOCK
(x10) | 5/16

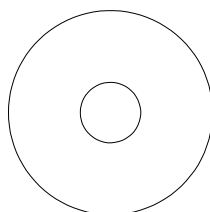

H100105 | WASHER FLAT
(x16) | 8x27

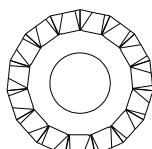

H100030 | WASHER LOCK EXT
(x92) | 8x19



H100072 | T-NUT
(x22) | 1/4

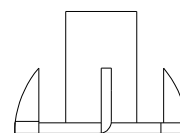

H100074 | T-NUT
(x85) | 5/16

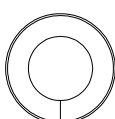

H100095 | WASHER SPLIT
(x4) | 5/16

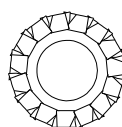

H100138 | WASHER LOCK EXT
(x17) | 6x15

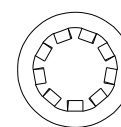

H100108 | WASHER LOCK INT
(x19) | 8x15

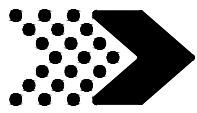

Hardware Components

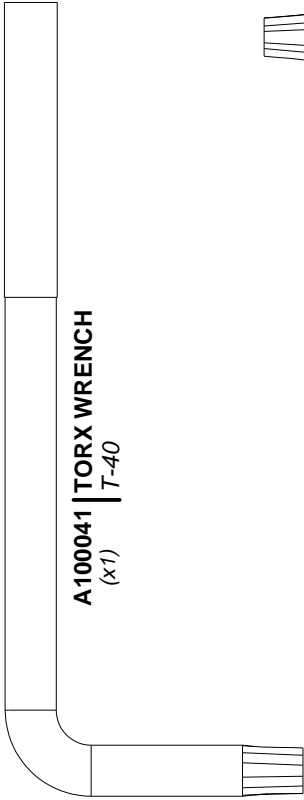

A100041 | TORX WRENCH
(x1) | T-40

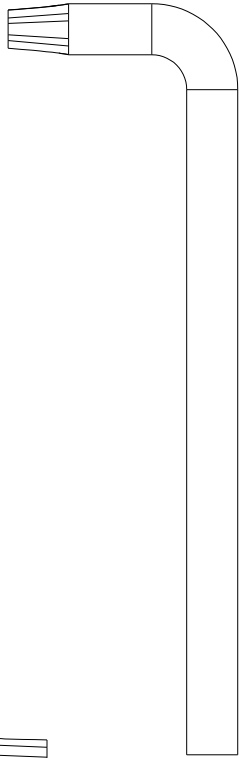

H100114 | TORX WRENCH
(x1) | T-30

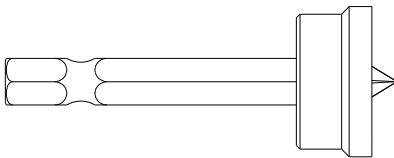

H100764 | SCREW SETTER
(x1)

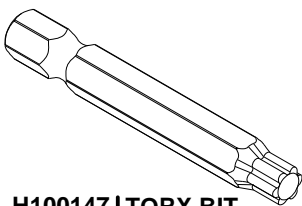

H100147 | TORX BIT
(x1) | T-30

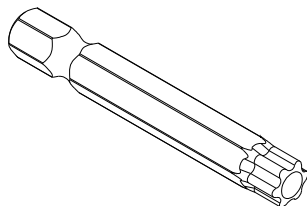

A100042 | TORX BIT
(x1) | T-40

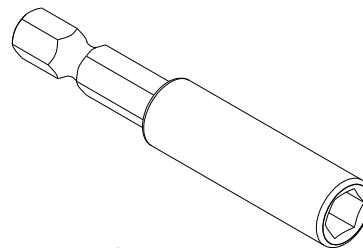

H101100 | MAGNETIC DRIVER
(x1)

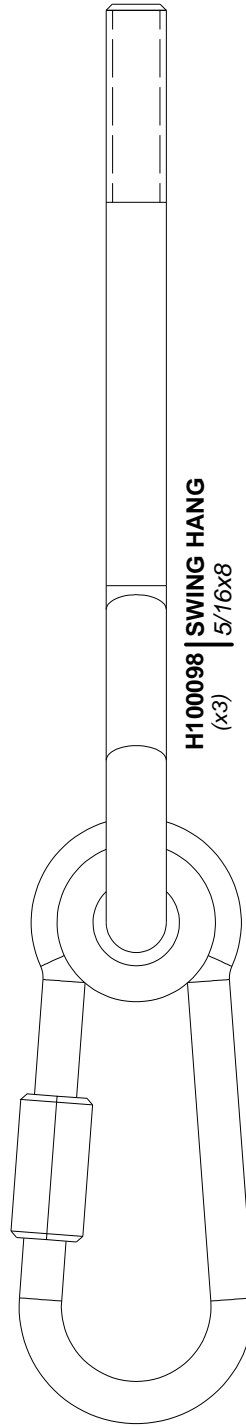

H100098 | SWING HANG
(x3) | 5/16x8

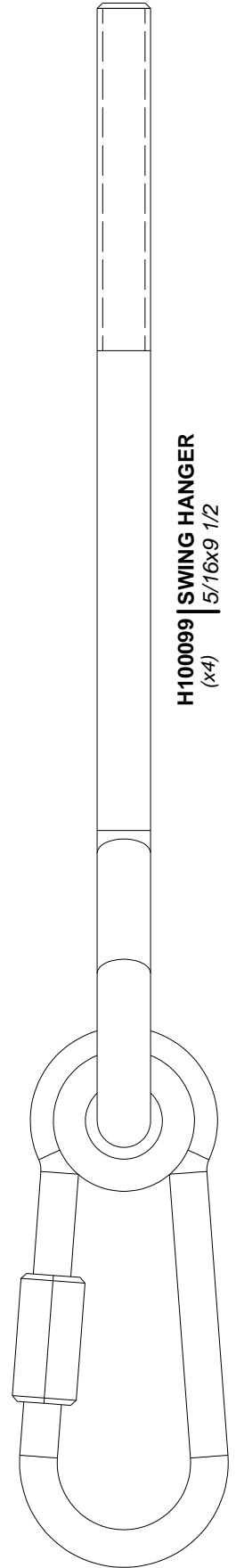

H100099 | SWING HANGER
(x4) | 5/16x9 1/2

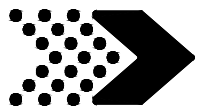

Accessory Components (Not to Scale)

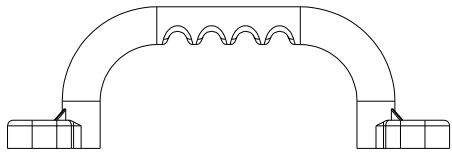

A100028 | HAND GRIP GREEN PLASTIC
(x4)



A100134 | HAND GRIP GREEN 816 C/C
(x2)

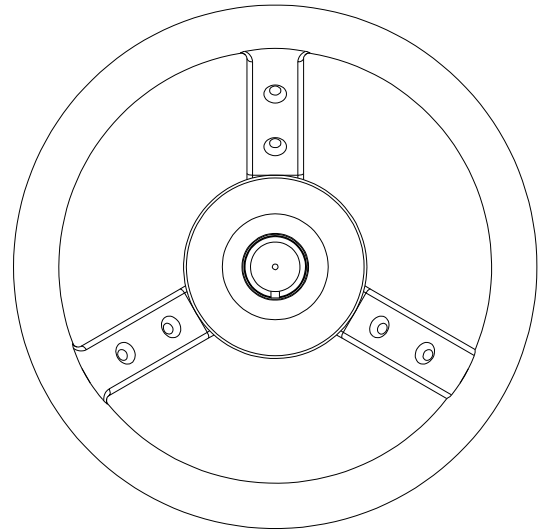

A100107 | STEERING WHEEL
(x1)

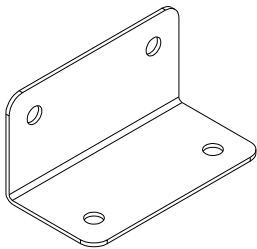

A100140 | L BRACKET 66x66x127
(x3)



A100164 | BYD ID TAG (LARGE) AGES 3-10
(x1)

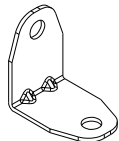

A4M01046 | L BRACKET 2.5x38x55x55
(x8)



A6P00037 | GREEN HC ROCK #2
(x9)

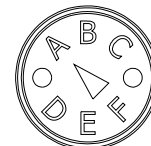

A100314 | "A" REVISION TAG
(x1)

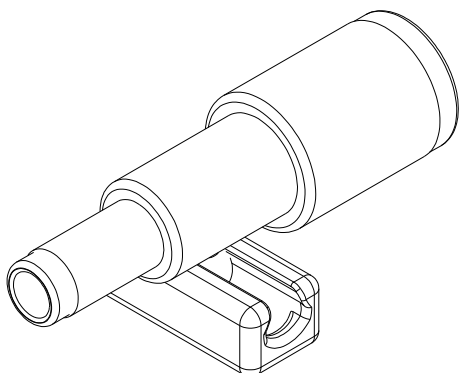

A6P00096 | TELESCOPE
(x1)

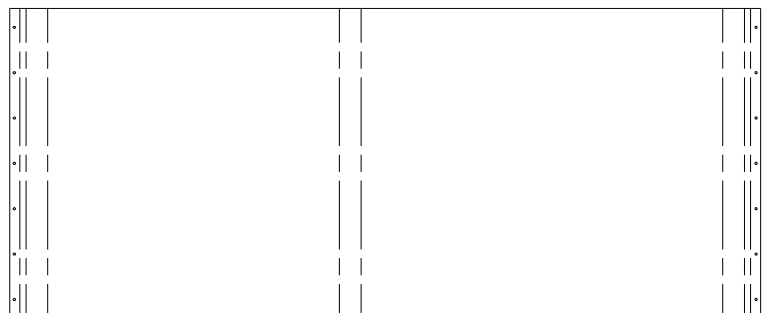

A6P00157 | TARP
(x1)

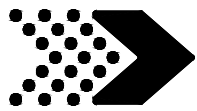

Accessory Components (Not to Scale)

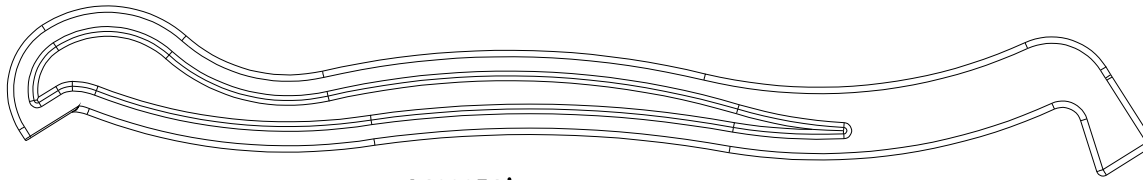

A100054 (x1) | SLIDE RAIL 8' GREEN RIGHT

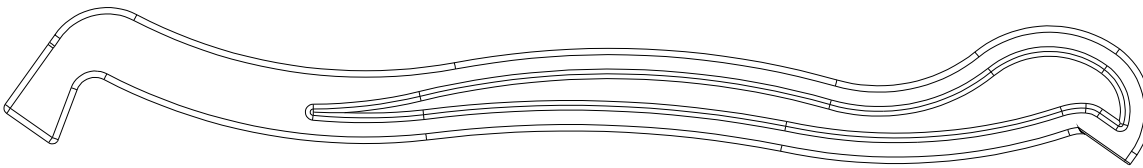

A100055 (x1) | SLIDE RAIL 8' GREEN LEFT

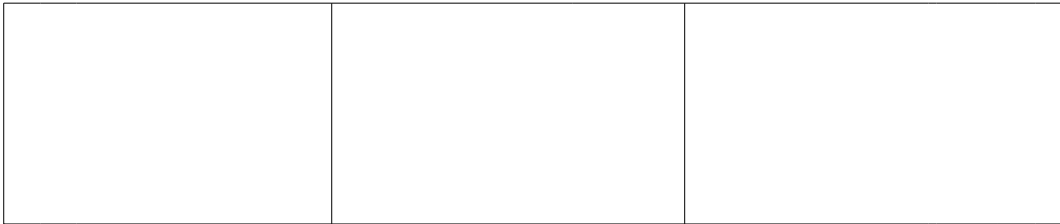

A6P00386 (x1) | SLIDE BED 8' DARK GREEN

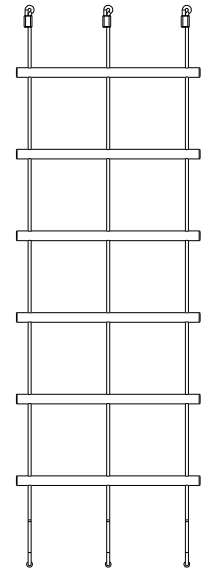

A6P00161 (x1) | ROPE LADDER

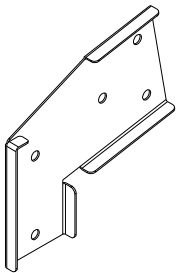

A100325 (x1) | SWING BEAM EXTENSION BRACKET-LEFT

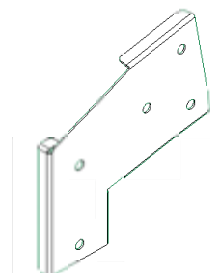

A100326 (x1) | SWING BEAM EXTENSION BRACKET-RIGHT

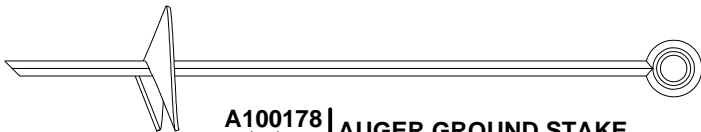

A100178 (x7) | AUGER GROUND STAKE

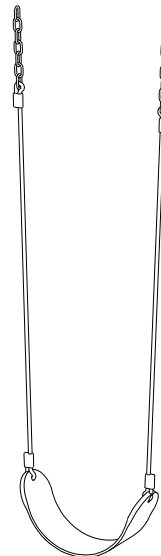

A6P00397 (x1) | ROPE-CHAIN GR / SEAT GR 22"



A4M01415 (x1) | 26" WEB SWING (EU)

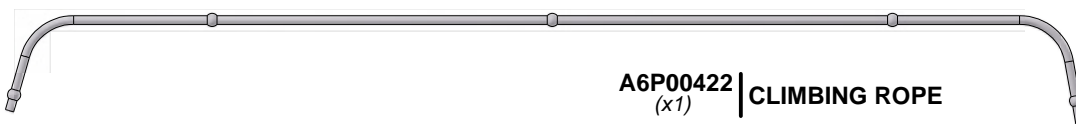

A6P00422 (x1) | CLIMBING ROPE

PRE-ASSEMBLY STEP 1 - SORTING PARTS

It is critical for ease of assembly that you take the time to sort and organize the wood and hardware.

WOOD PARTS:

- Organize wood parts by the three-digit, alpha-numeric number stamped on each board (ex. P01).
- If there are multiple boards with the same stamped number, stack those pieces together.
- Stamps can be found on the flat surface of the boards or on the end of the boards.
- Allow yourself plenty of room - the wood pieces can take up a significant amount of space.

NOTE: CARTONS ARE NOT ORGANIZED BY BOARD NUMBER.

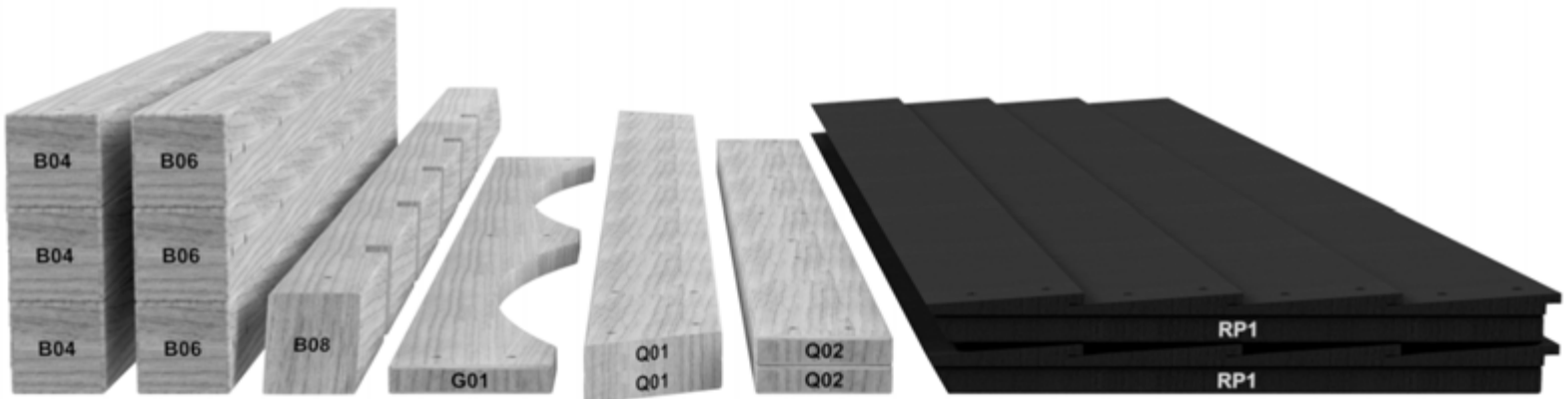

HARDWARE PARTS:

- We recommend that you have a separate table to organize the hardware.
- Hardware bags are printed with a seven-digit, alpha-numeric part number.
- You can organize your hardware by part number or group by hardware type (i.e. bolts, nuts, etc.).
- During assembly you only need to reference the last four digits of the number.

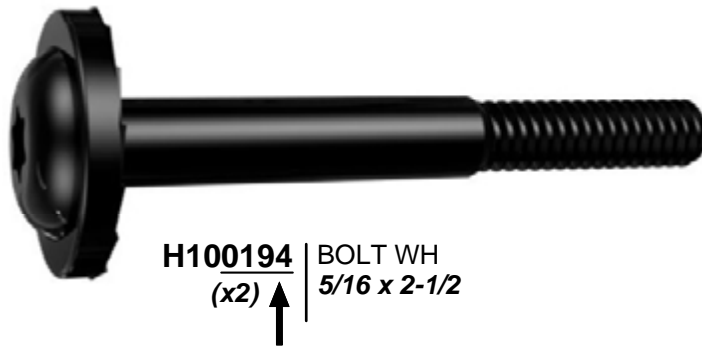

PRE-ASSEMBLY STEP 2 - TOOLS REQUIRED



Cordless Drill or
Electric Drill



Drill Attachments:
Phillips Head



1/8", 3/16", 3/8" & 7/16" Drill
Bits



Phillips Screw Driver



Open End Wrenches 1/2" & 9/16"



3/8" Drive Ratchet, 1/2" &
9/16" STD Sockets 1/2" & 9/16" Deep
Sockets



Claw Hammer



Rubber Mallet - Optional

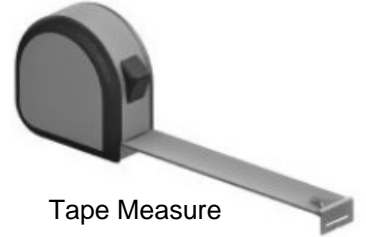

Tape Measure

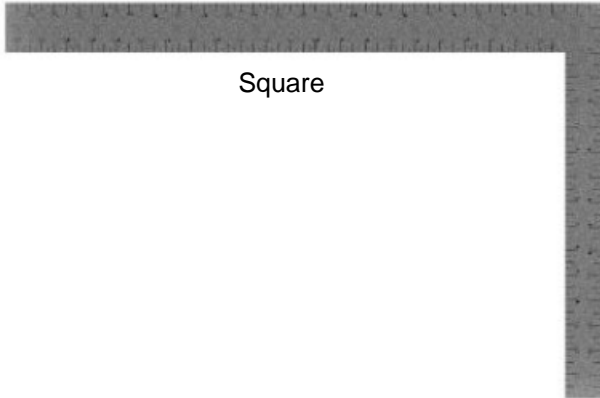

Square



Level 24"

PRE-ASSEMBLY STEP 3 - CHOOSE YOUR ASSEMBLY METHOD

There are several types of assembly instructions available to you.

1. Printed Assembly Manual included with your set
2. BILT APP - 3D interactive instructions
3. Combination of the Printed Manual and BILT APP (Note: Step numbers can differ between the two methods)

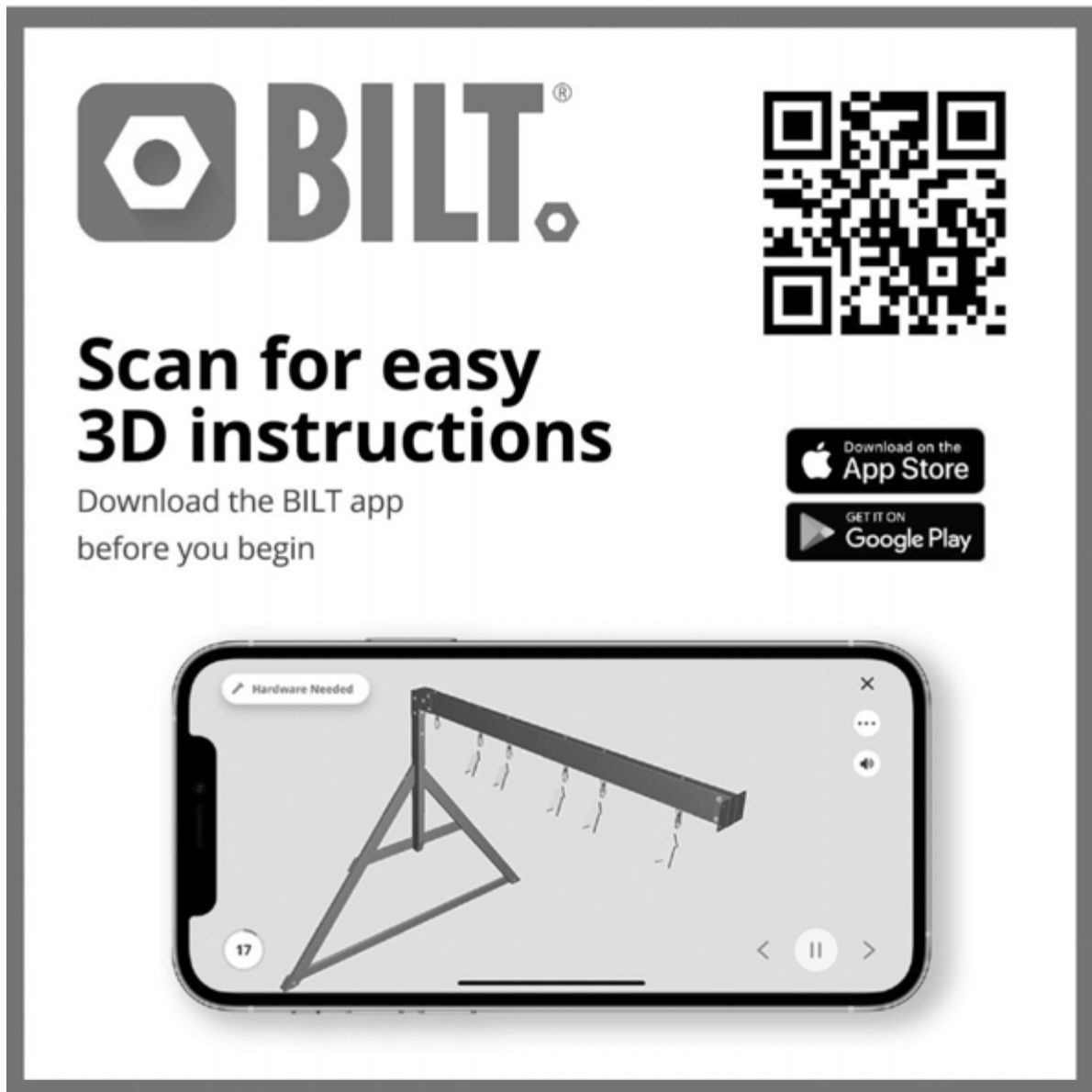

The advertisement features the BILT logo on the left, a QR code on the right, and a smartphone displaying a 3D assembly instruction. The text 'Scan for easy 3D instructions' is prominently displayed, along with download instructions for the App Store and Google Play.

BILT.[®]

**Scan for easy
3D instructions**

Download the BILT app
before you begin

Download on the
App Store

GET IT ON
Google Play

Hardware Needed

17



SLIDE ASSEMBLY

STEP 1



A6P00386 | SLIDE BED 8' DARK GREEN
(x1)

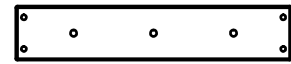

M77 | SLIDE BRACE - W4L08748
(x1) | 5/8"x3 3/8"x17 1/4" (16x86x438)



H100115 | BOLT WH
(x3) | 5/16x1/2



H100074 | T-NUT
(x3) | 5/16

NOTE: TAKE NOTE OF SLIDE BED SURFACE FINISH, THE DULL SIDE WILL BE TOWARDS THE GROUND. PLACE SLIDE BRACE CENTERED ON THE BOTTOM (DULL SIDE) AND 1/4" FROM THE EDGE. USE M77 BOARD AS A TEMPLATE FOR DRILLING BOTTOM HOLE PATTERN IN SLIDE BED. USE A 5/16" DRILL BIT.

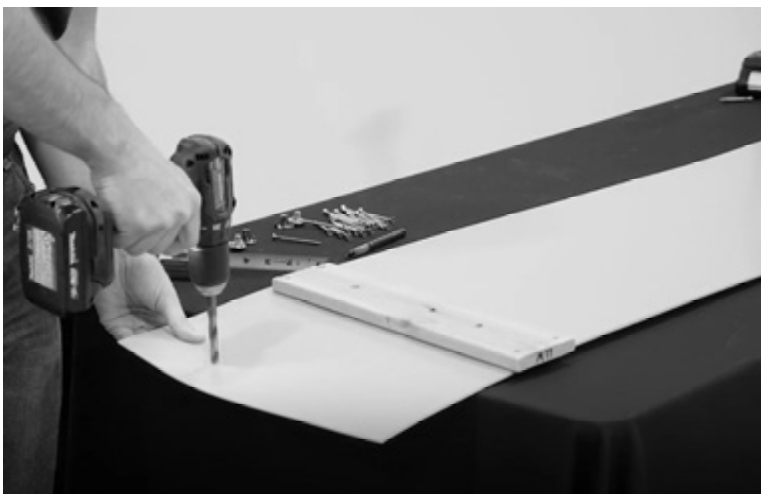
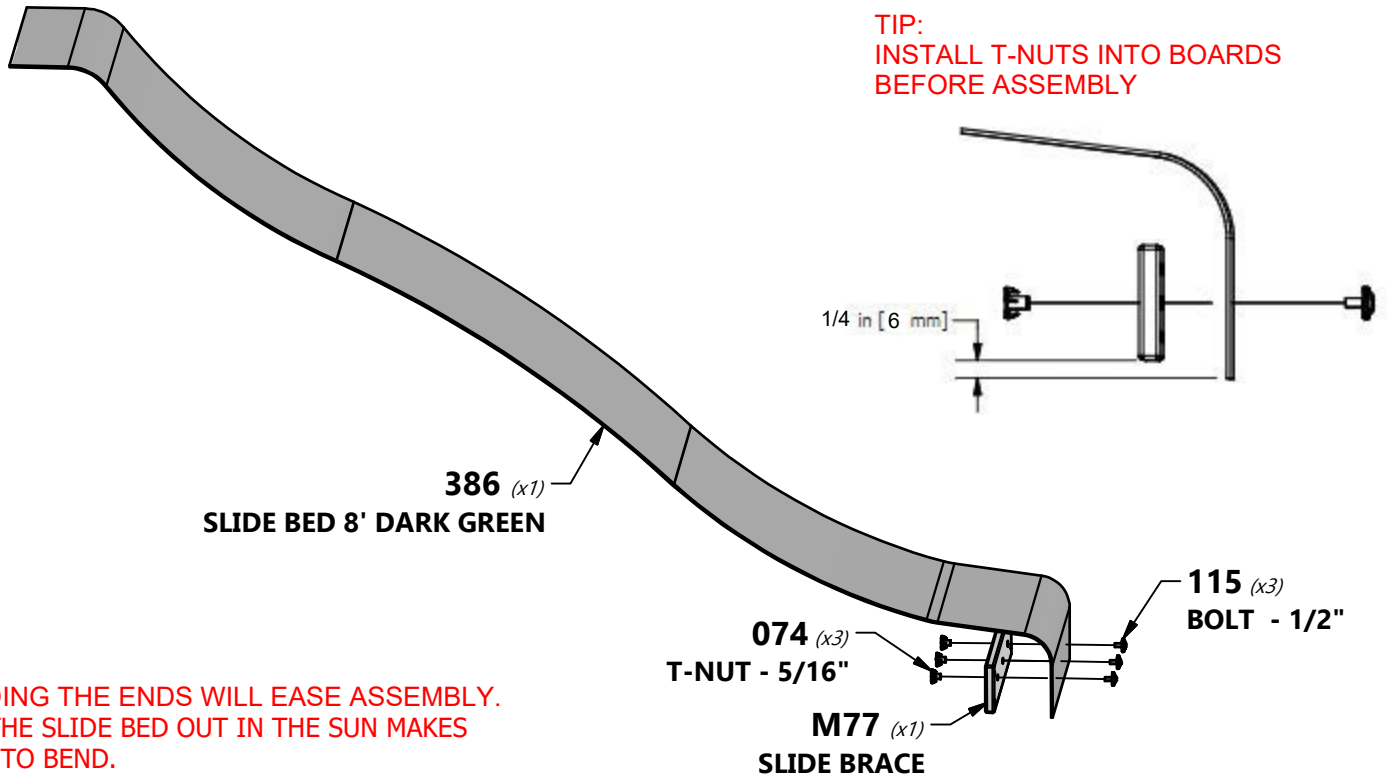



SLIDE ASSEMBLY

STEP 2



M78 | CENTER SLIDE BRACE - W4L08749
(x2) | 5/8"x3 3/8"x17 1/4" (16x86x438)



A100054 | SLIDE RAIL 8' GREEN RIGHT
(x1)



A100055 | SLIDE RAIL 8' GREEN LEFT
(x1)



H100090 | SCREW PFH
(x24) | 8x2-1/2

NOTE:
PLACE THE SLIDE RAIL ON FLAT SURFACE. STARTING AT THE BOTTOM, INSERT THE SLIDE BED INTO THE CHANNEL ON THE INSIDE OF THE RAIL. HOLD THE SLIDE BED IN PLACE WHILE A HELPER BENDS THE SLIDE BED INTO THE CHANNEL. MAKE SURE THE SLIDE BED IS COMPLETELY INSERTED INTO THE CHANNEL.

INSERT THE TWO CENTER SLIDE BRACES INTO THEIR RESPECTIVE LOCATIONS. SECURE THE SLIDE BED AND CENTER USING THE PROVIDED HARDWARE.

USING A 1/8" DRILL BIT, DRILL PILOT HOLES IN EACH INDENTATION ALONG EACH SIDE RAIL. THERE SHOULD BE 12 INDENTIONS ON EACH RAIL.

REPEAT THIS PROCESS FOR THE OPPOSITE SLIDE RAIL.



FAILURE TO INSERT SLIDE BED PROPERLY MAY RESULT IN INJURY OR AMPUTATION. EXPOSED SLIDE EDGES CAN BE SHARP AND BECOME A LACERATION HAZARD IF THE SLIDE IS NOT PROPERLY ASSEMBLED.

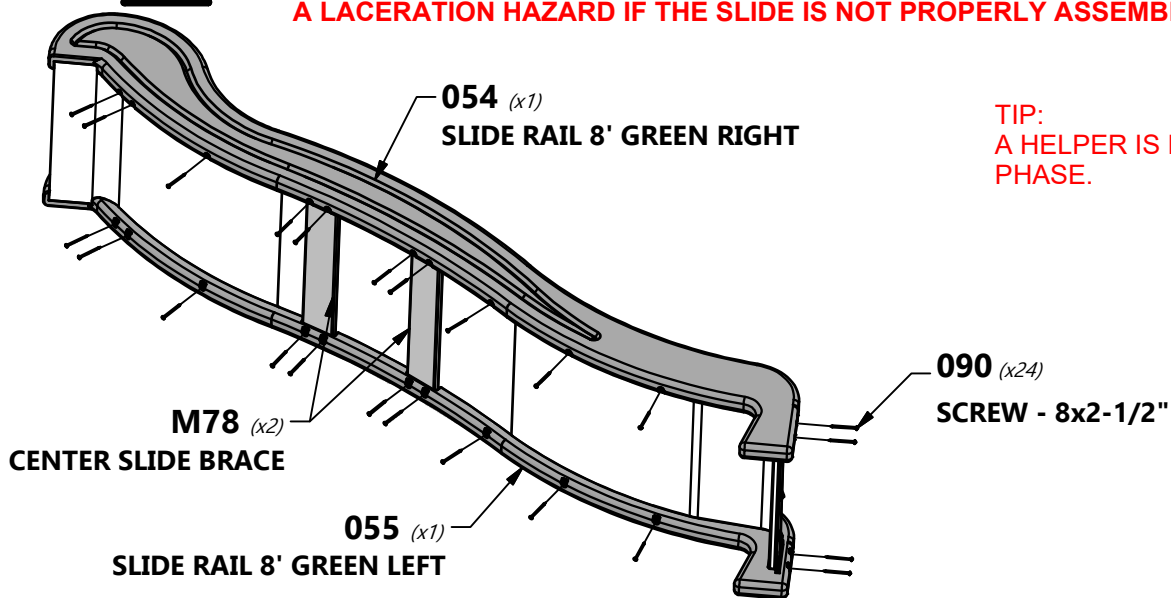

TIP:
A HELPER IS REQUIRED FOR THIS PHASE.

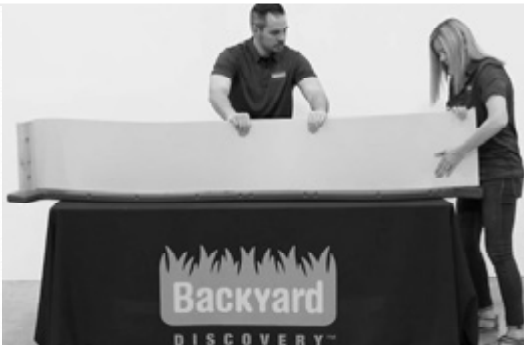



E74 | LEFT UPRIGHT - W4L13775
(x1) | 1 3/8"x3 3/8"x50 3/4" (36x86x1290)



H81 | LADDER RUNG - W4L13778
(x4) | 1"x3 3/8"x17 1/8" (24x86x434)



H100111 | SCREW PFH
(x8) | 8x2

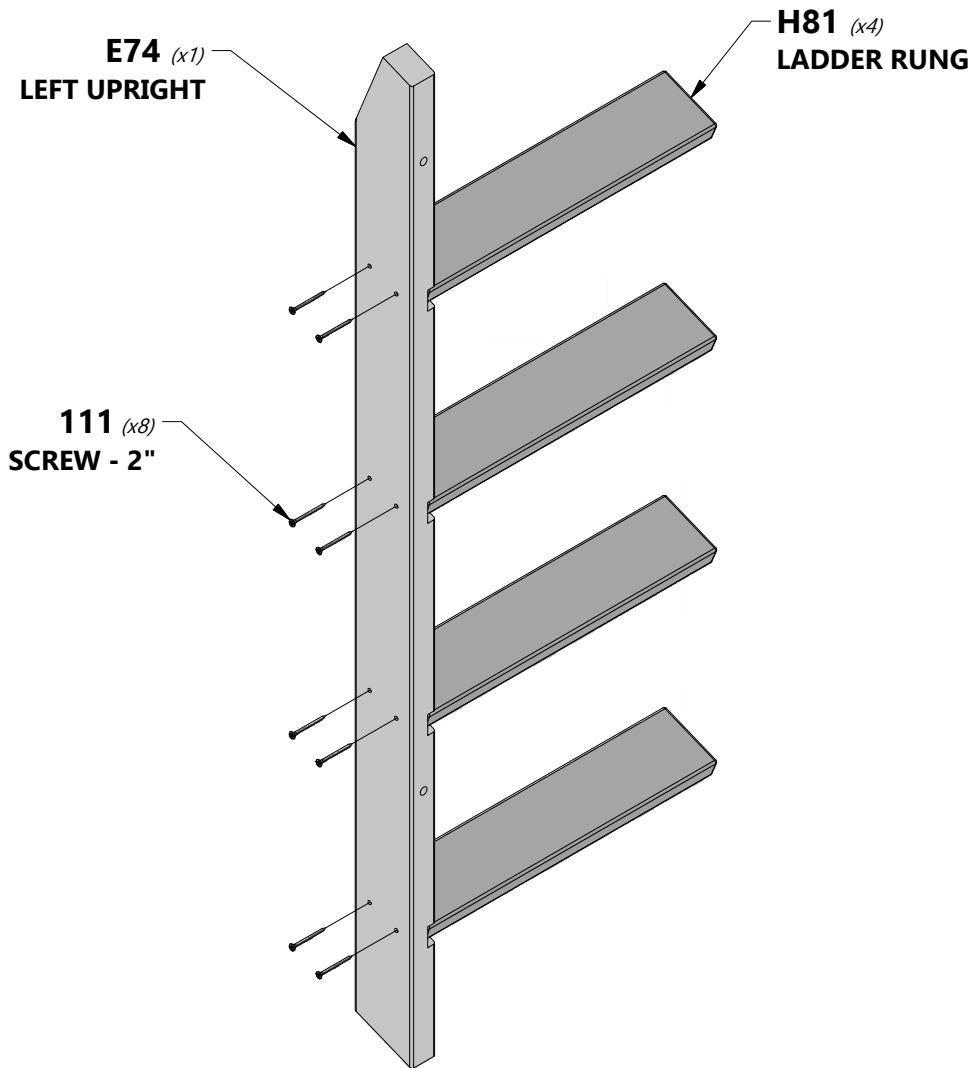

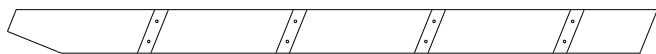

E75 | RIGHT UPRIGHT - W4L13776
(x1) | 1 3/8"x3 3/8"x50 3/4" (36x86x1290)



H100111 | SCREW PFH
(x8) | 8x2

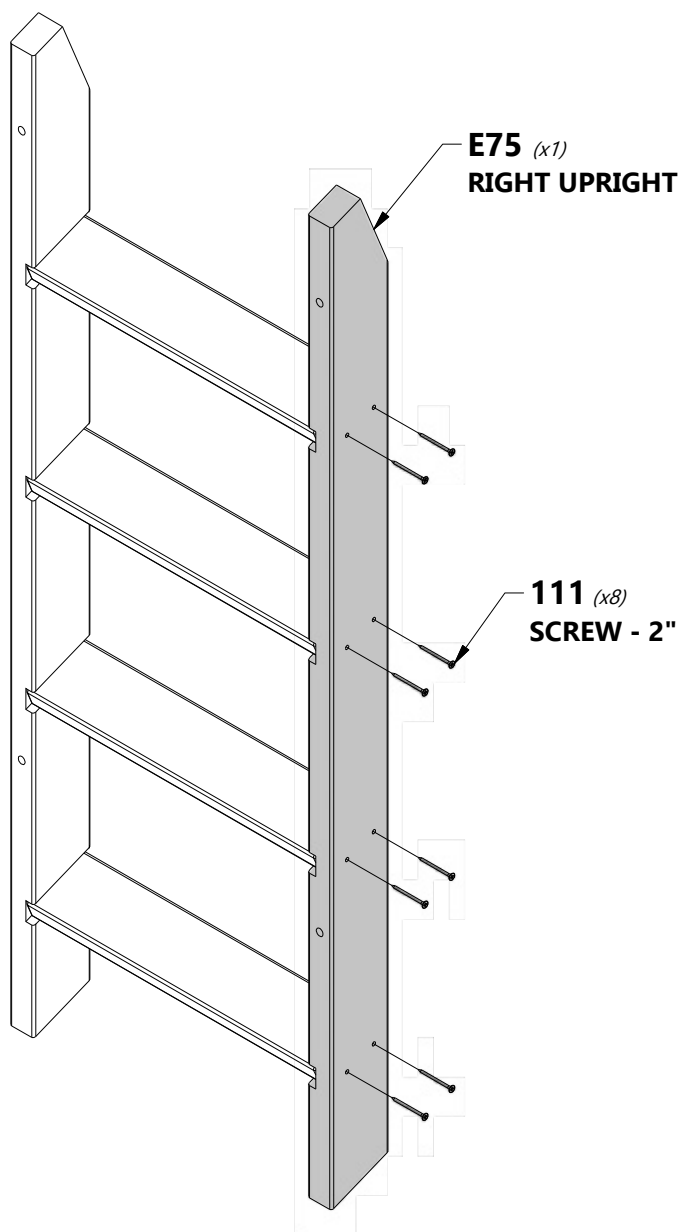



M103 REAR SUPPORT - W4L13777
(x1) 5/8"x3 3/8"x19" (16x86x482)



M102 ATTACHMENT BOARD - W4L13779
(x1) 5/8"x3 3/8"x19" (16x86x482)



H100086 SCREW PFH
(x8) 8x1 1/2

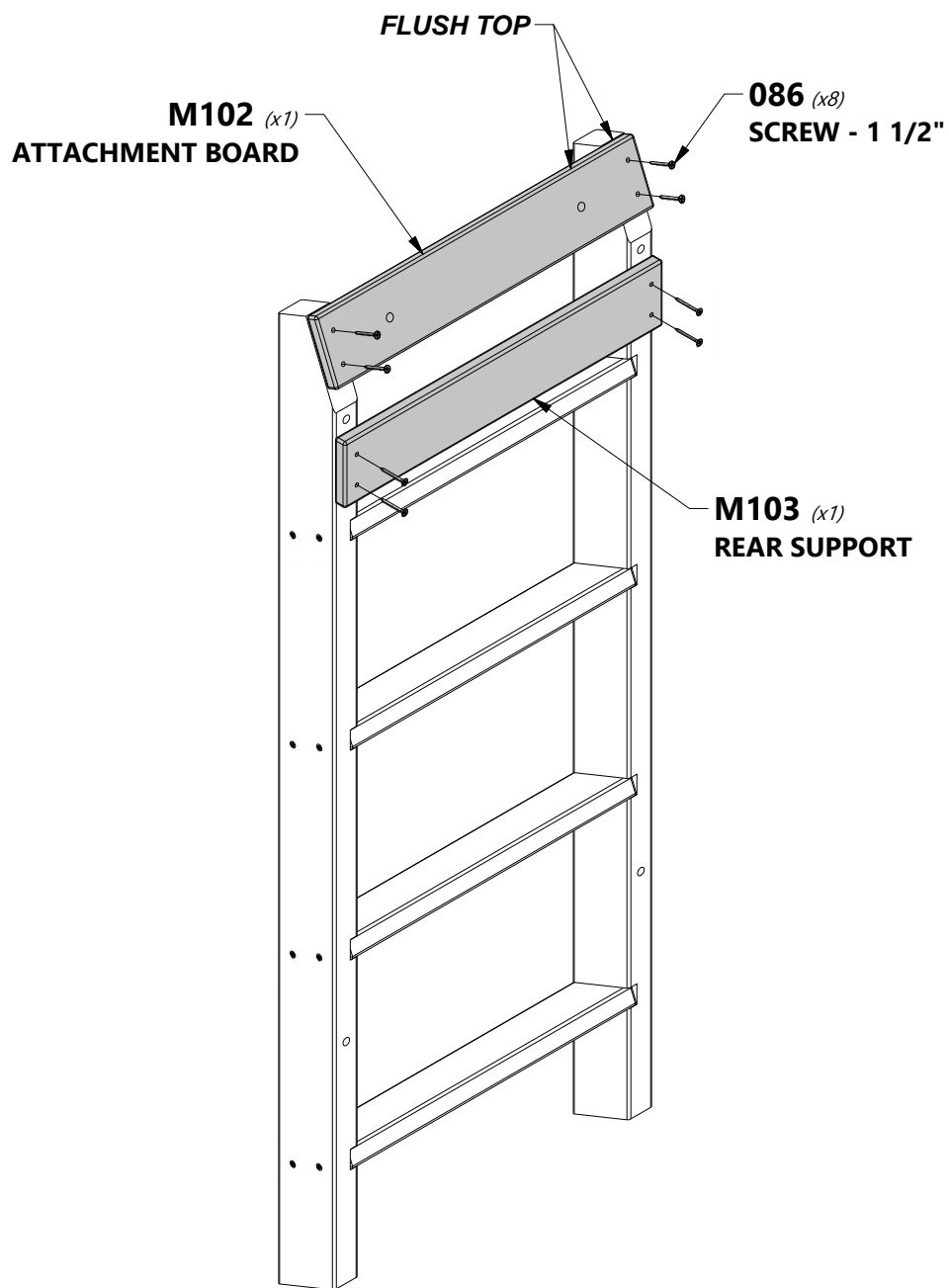

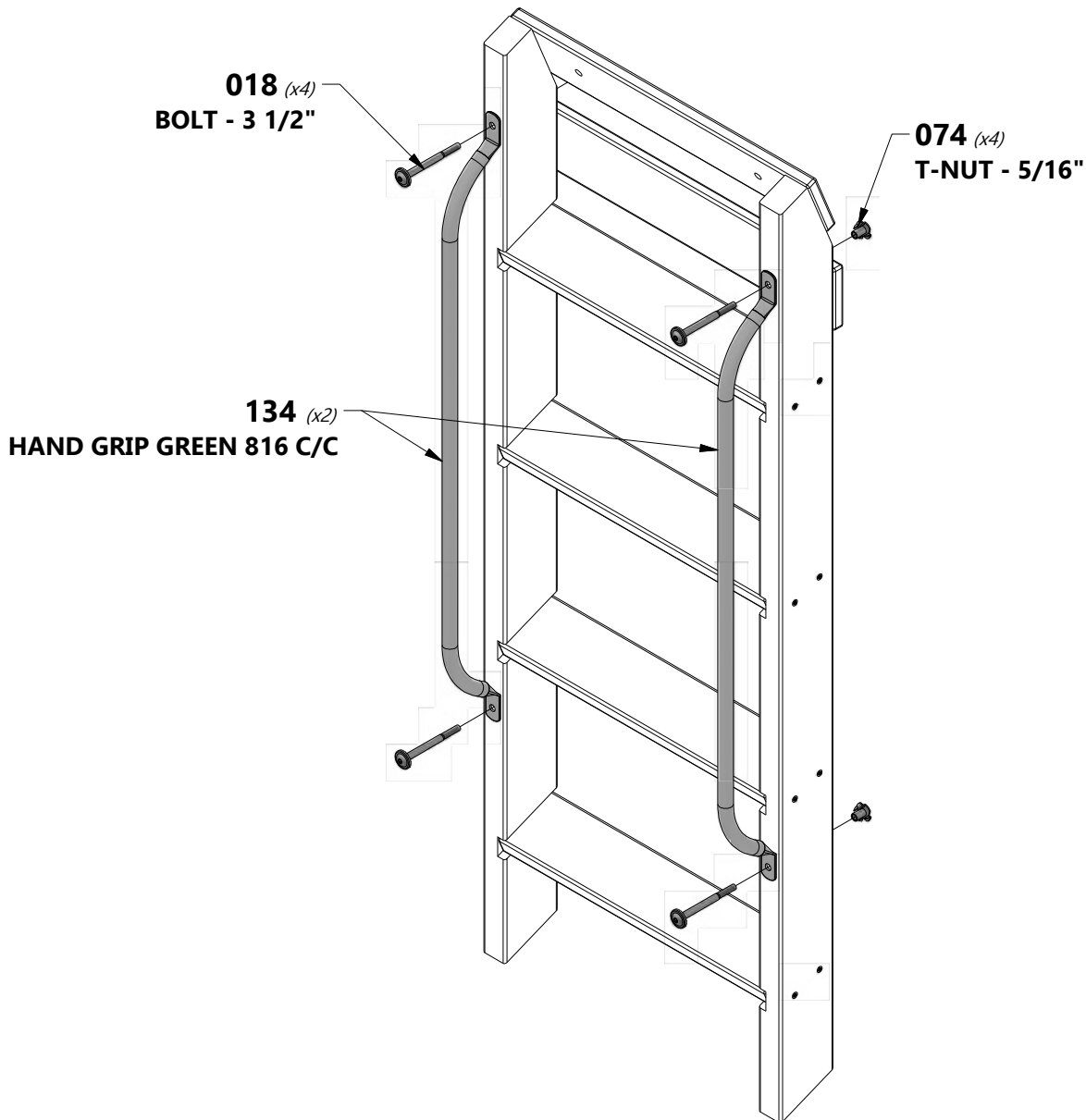
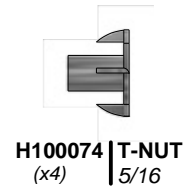
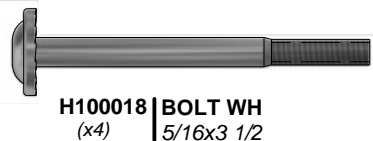



SWING BEAM

STEP 1

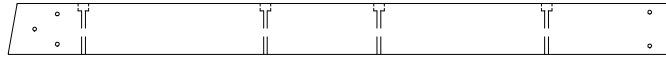

SB74 | SWING BEAM 2 POSITION - W4L13780
(x1) | 2"x5 1/4"x68 3/4" (50x134x1745)

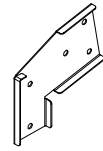

A100325 | SWING BEAM
EXTENSION
BRACKET-LEFT
(x1)

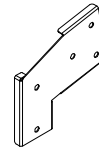

A100326 | SWING BEAM
EXTENSION
BRACKET-RIGHT
(x1)

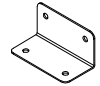

A100140 | L BRACKET
(x2) | 66x66x127



H100047 | BOLT HEX
(x2) | 5/16x2 3/4

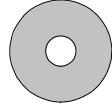

H100105 | WASHER FLAT
(x4) | 8x27



H100110 | NUT LOCK
(x2) | 5/16



H100011 | BOLT WH
(x3) | 5/16x1 3/4

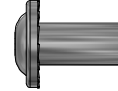

H100005 | NUT BARREL WH
(x3) | 5/16x7/8

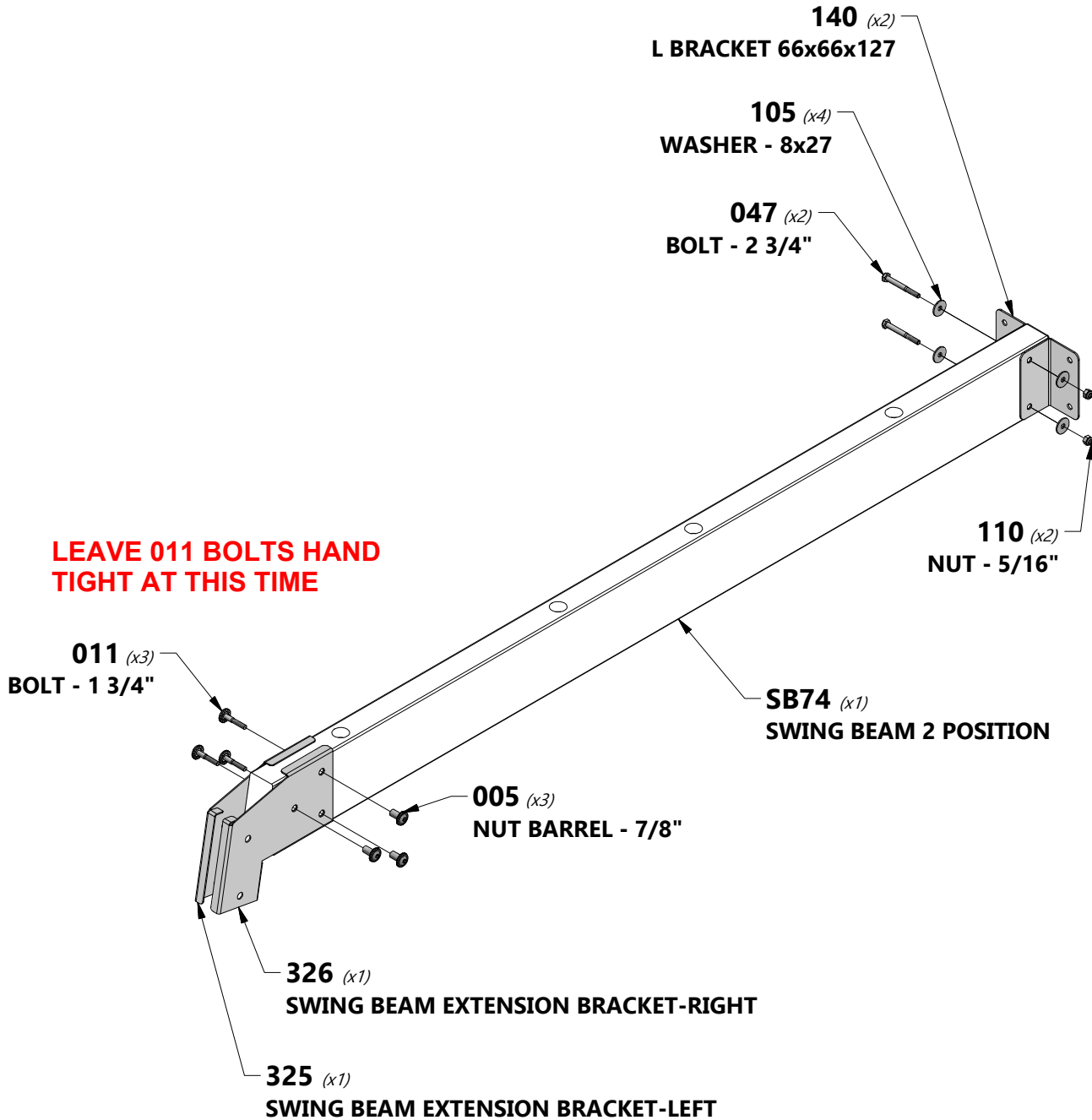



SWING BEAM

STEP 2

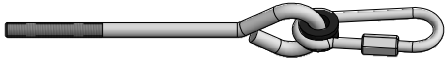

H100099 | SWING HANGER
(x4) | 5/16x9 1/2

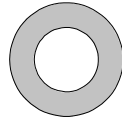

H100103 | WASHER SAFETY
(x4) | 17x30

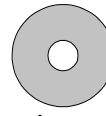

H100105 | WASHER FLAT
(x4) | 8x27



H100110 | NUT LOCK
(x4) | 5/16

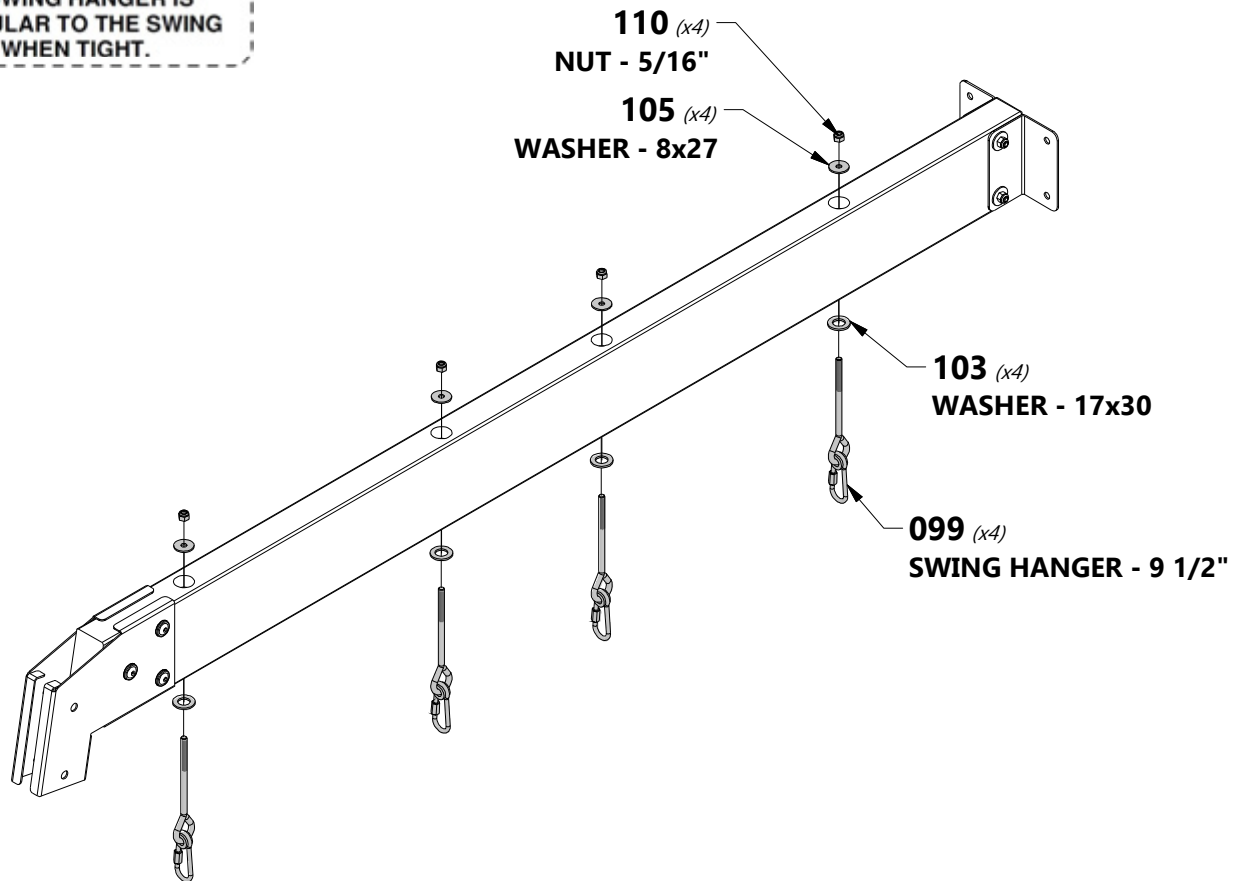
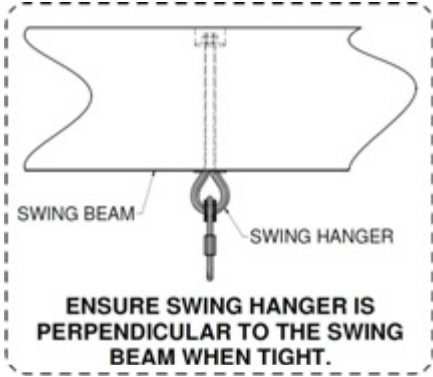



SWING BEAM

STEP 3

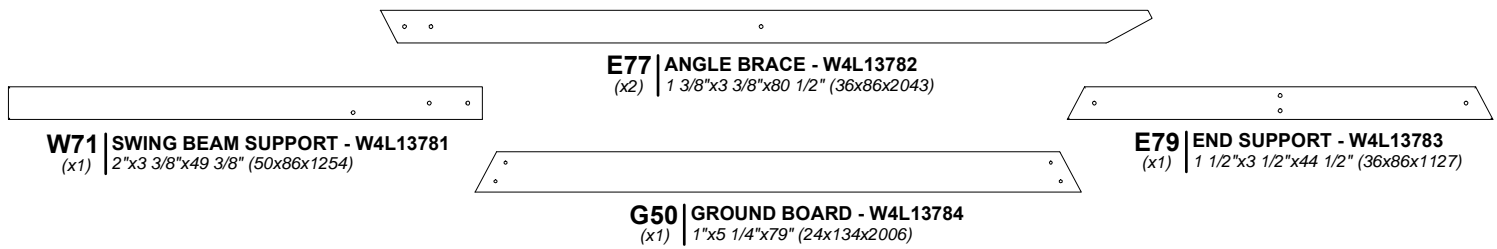

H100021 | BOLT WH
(x1) | 5/16x4 1/2



H100013 | BOLT WH
(x4) | 5/16x2 1/4



H100505 | BOLT WH
(x2) | 5/16x4 3/4



H100074 | T-NUT
(x8) | 5/16

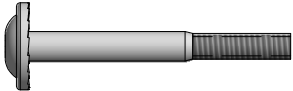

H100015 | BOLT WH
(x2) | 5/16x2 3/4



H100031 | WASHER LOCK EXT
(x1) | 12x19



H100030 | WASHER LOCK EXT
(x9) | 8x19

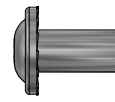

H100005 | NUT BARREL WH
(x1) | 5/16x7/8

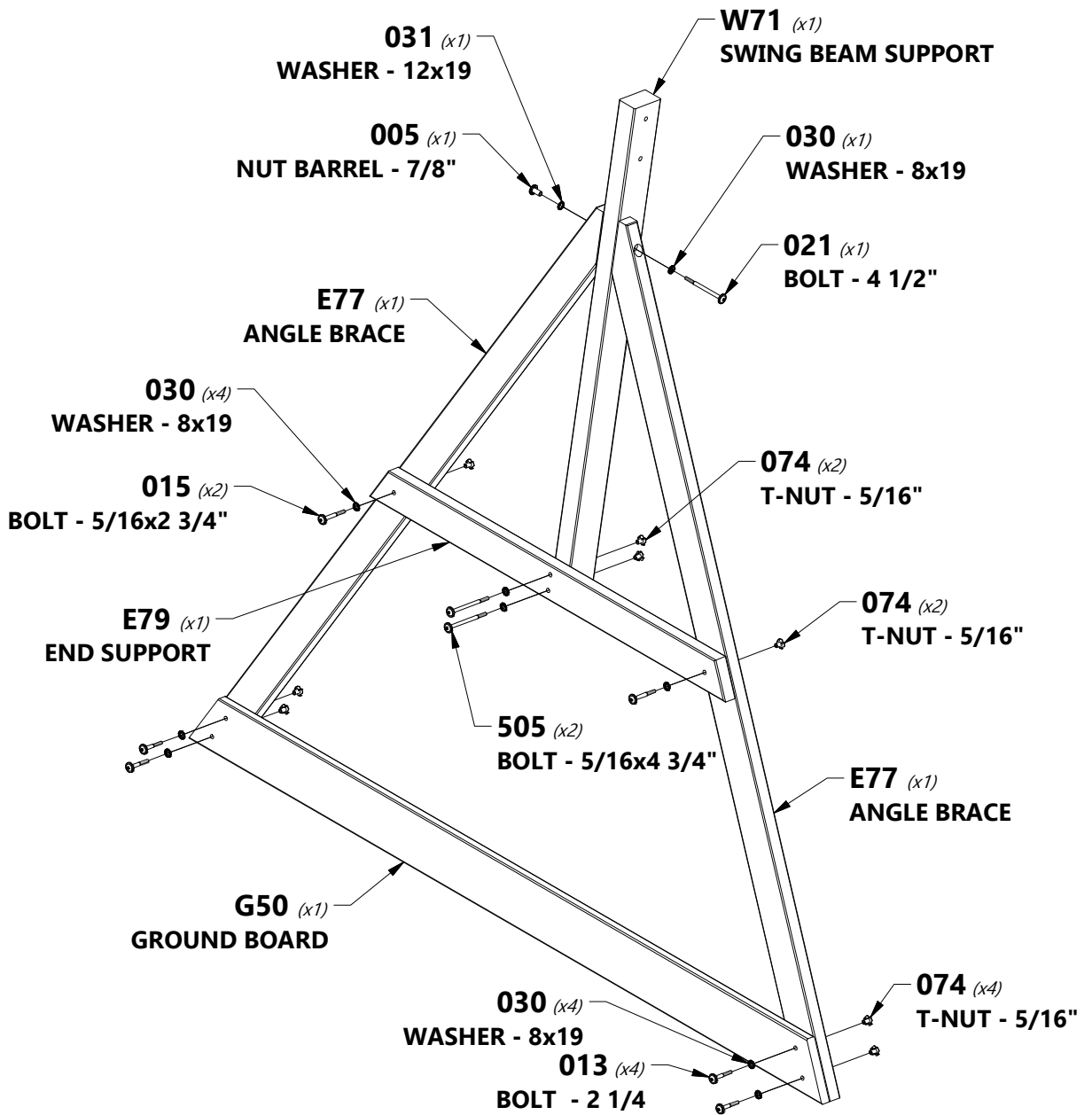



SWING BEAM

STEP 4

SWING BEAM SUB ASSEMBLY
(FROM STEP 2)



H100011 | BOLT WH
(x2) | 5/16x1 3/4

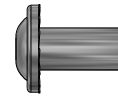

H100005 | NUT BARREL WH
(x2) | 5/16x7/8

'A' FRAME SUB ASSEMBLY
(FROM STEP 3)

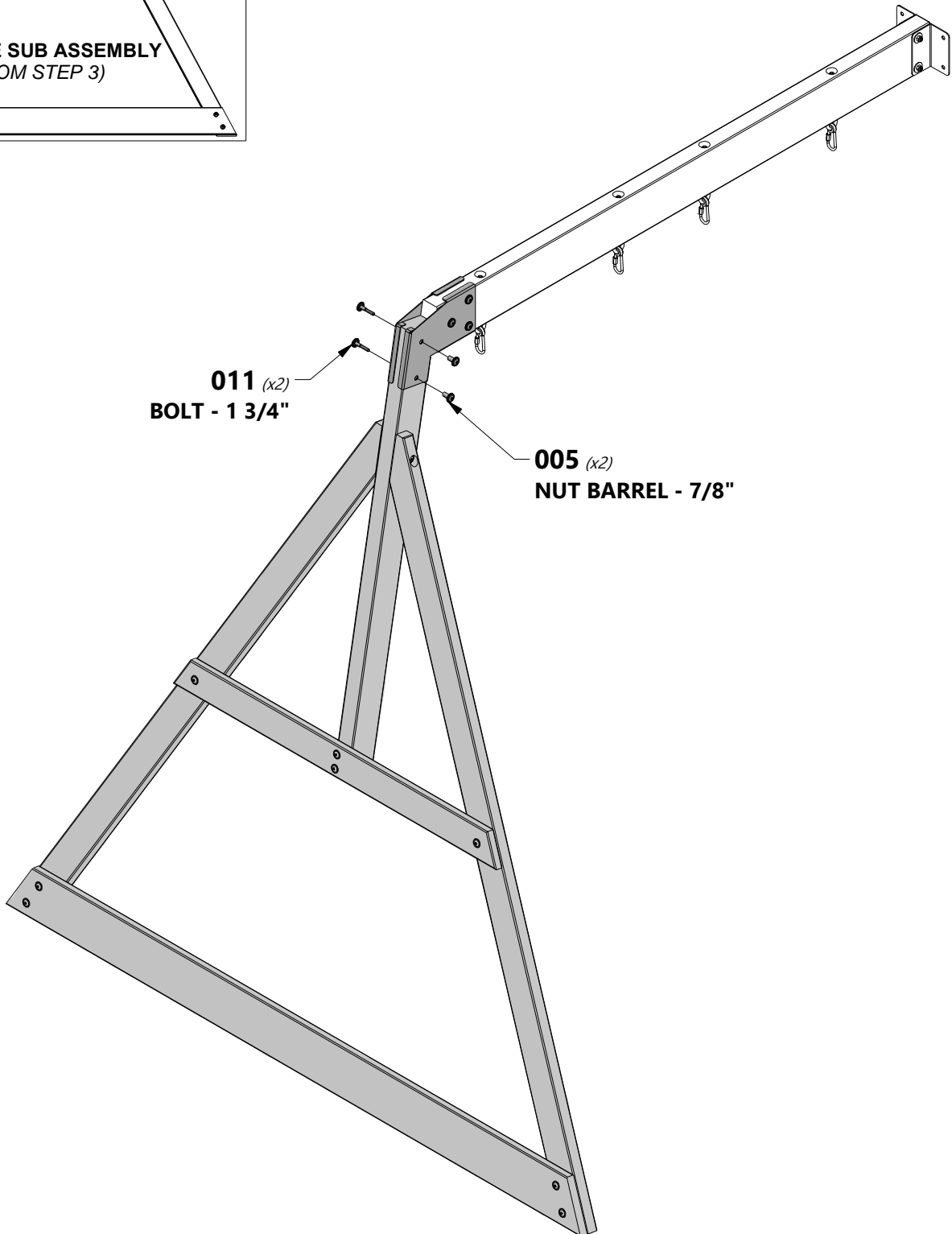

011 (x2)
BOLT - 1 3/4"

005 (x2)
NUT BARREL - 7/8"



B1 | UPRIGHT POST ASSEMBLY - W2A02851
(x1) | 3"x3"x89 1/2" (76x76x2274)

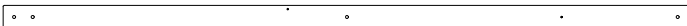

B4 | UPRIGHT POST - W4L13770
(x1) | 3"x3"x89 1/2" (76x76x2274)



H100074 | T-NUT
(x16) | 5/16



TIP:

1. FOR EASE OF ASSEMBLY WE RECOMMEND USING SAW HORSES TO ASSEMBLE FORT WALLS.
2. WE RECOMMEND INSTALLING T-NUTS INTO BOARDS BEFORE ASSEMBLY.

NOTE PILOT HOLE LOCATION FOR PROPER ORIENTATION OF THE POST.

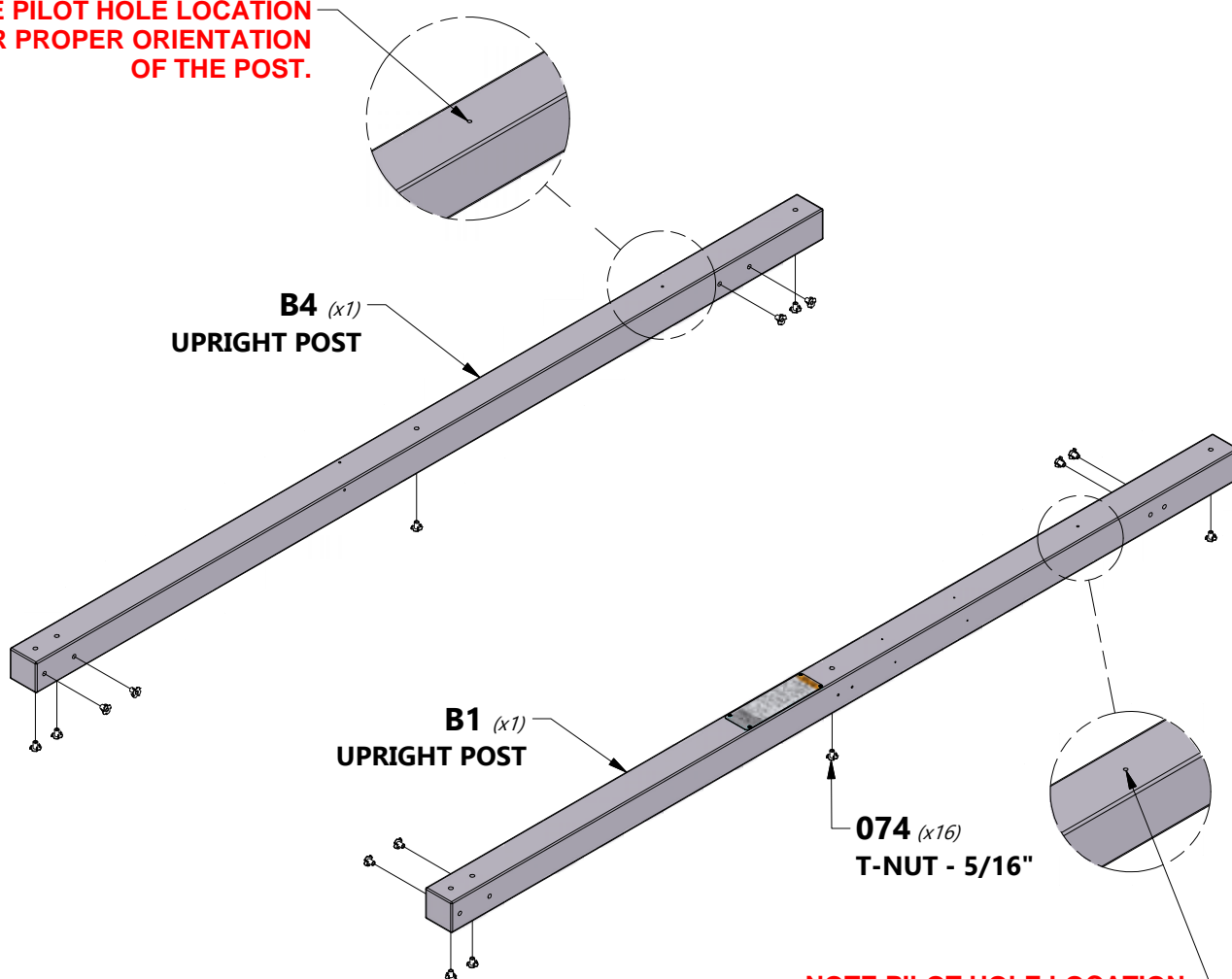

NOTE PILOT HOLE LOCATION FOR PROPER ORIENTATION OF THE POST.



H2 | FLOOR SUPPORT - W4L13772
(x1) | 1"x3 3/8"x52 1/8" (24x86x1324)

H12 | DECK BRACE - W4L13771
(x2) | 1"x3 3/8"x15 7/8" (24x86x402)

H8 | ROOF RAIL - W4L13765
(x1) | 1"x3 3/8"x83 7/8" (24x86x2132)

H13 | ARCHED RAIL - W4L13774
(x1) | 1"x3 3/8"x50 7/8" (24x86x1292)

K1 | GROUND BOARD - W4L07122
(x1) | 5/8"x5 1/4"x74 1/4" (16x134x1888)

ASSEMBLE T-NUT INTO ONLY (1) H12 DECK BRACE.

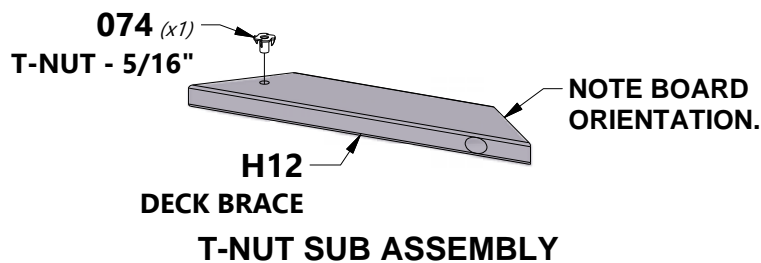

TIP:
INSTALL T-NUTS IN WOOD FIRST

H100019 | BOLT WH
(x4) | 5/16x3 3/4



H100030 | WASHER LOCK
(x12) | EXT
8x19

H100018 | BOLT WH
(x4) | 5/16x3 1/2



H100074 | T-NUT
(x4) | 5/16

H100011 | BOLT WH
(x2) | 5/16x1 3/4

H100028 | LAG SCREW WH
(x2) | 5/16x2 1/2



H100138 | WASHER LOCK
(x2) | EXT
6x15

H100146 | LAG SCREW WH
(x2) | 1/4x2

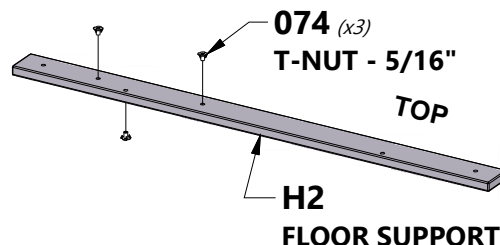

T-NUT SUB ASSEMBLY

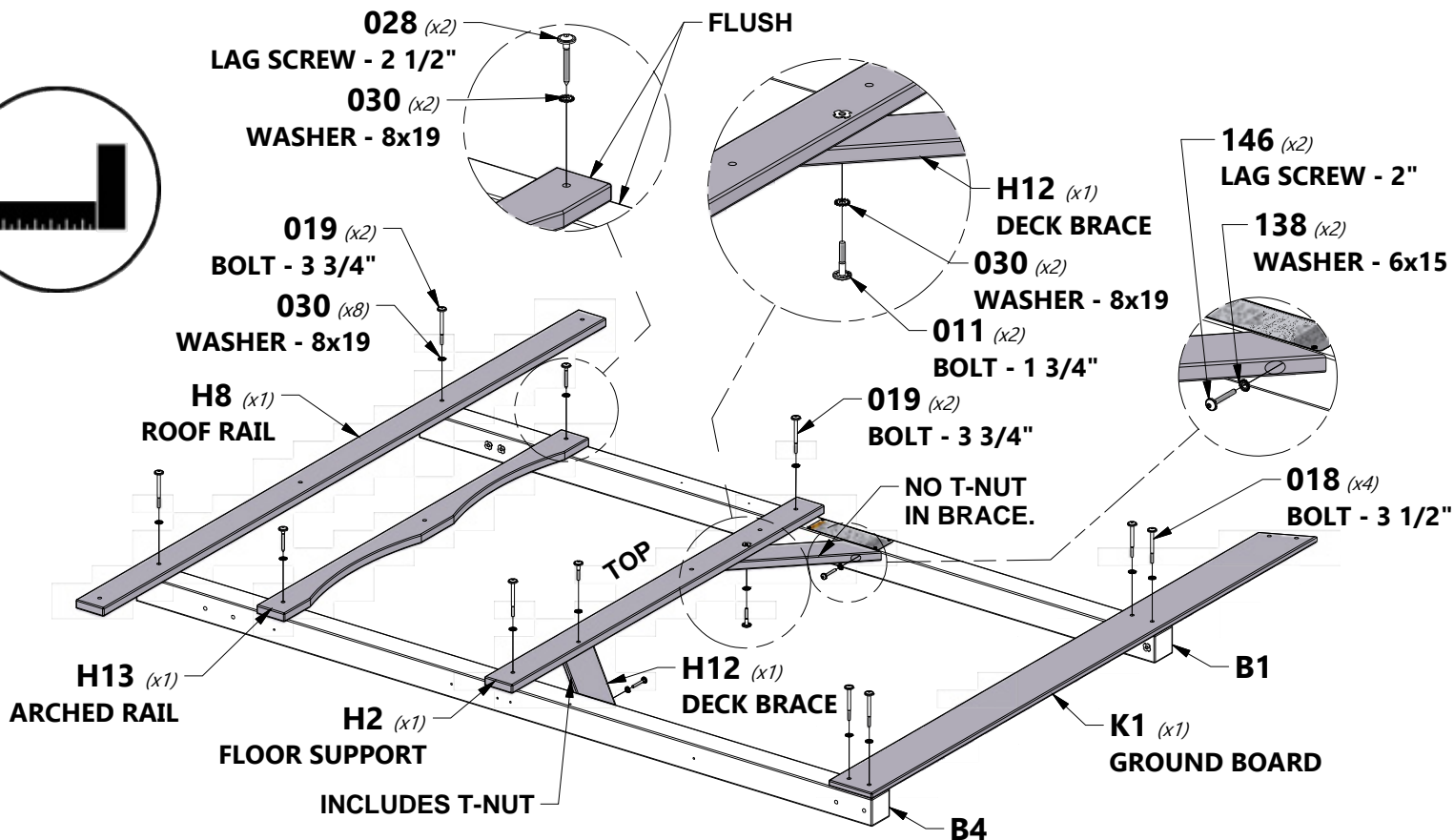
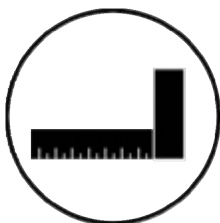

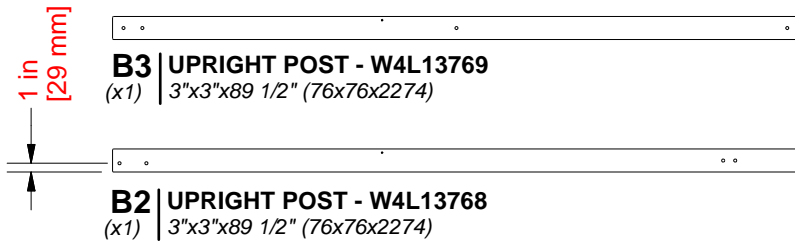
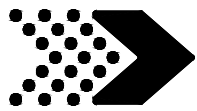

H100074 | T-NUT
(x16) | 5/16"

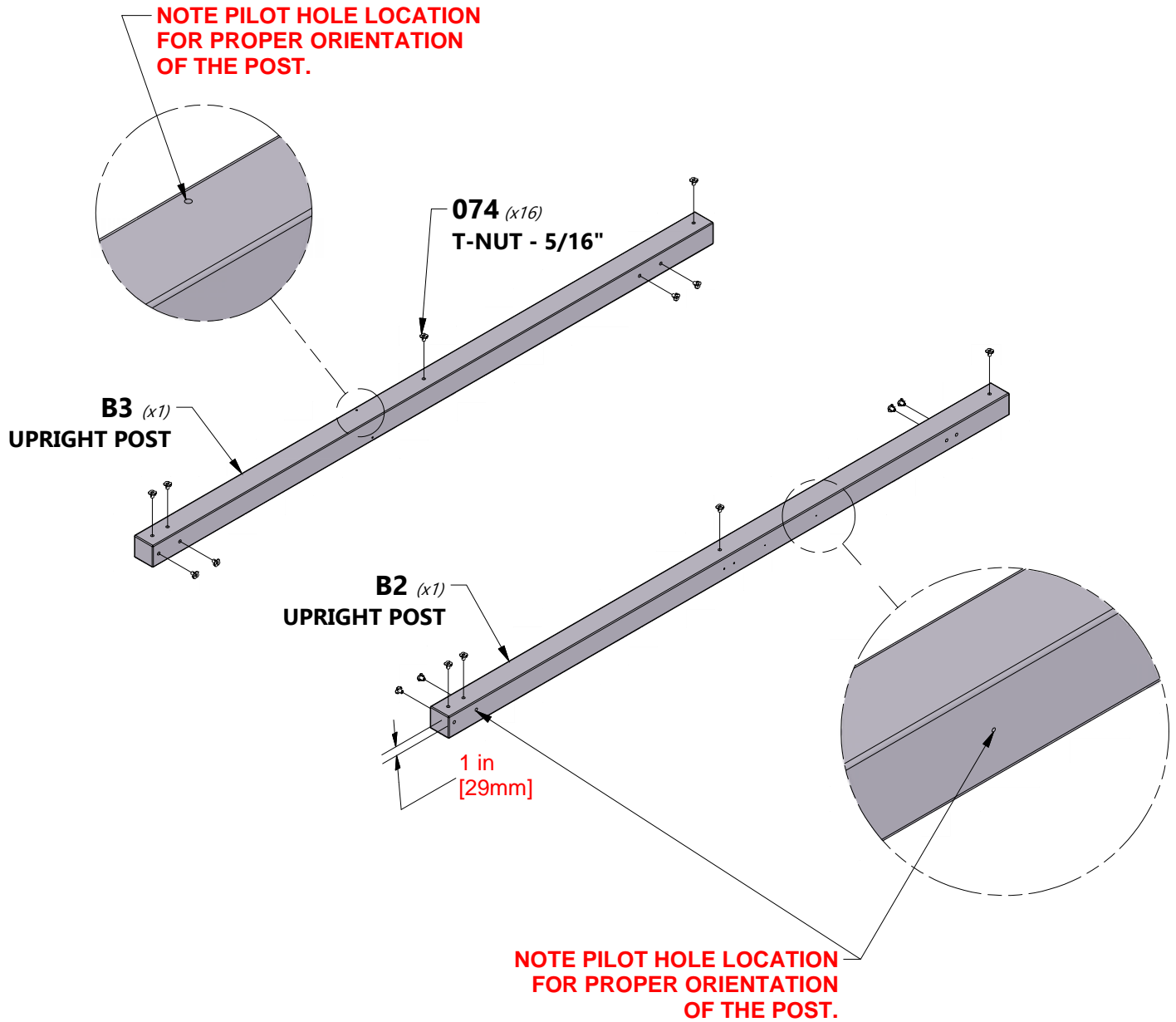



H3 | FLOOR SUPPORT - W4L13773
(x1) | 1"x3 3/8"x52 1/8" (24x86x1324)



H8 | ROOF RAIL - W4L13765
(x1) | 1"x3 3/8"x83 7/8" (24x86x2132)



K3 | GROUND BOARD - W4L07124
(x1) | 5/8"x5 1/4"x50 1/8" (16x134x1274)

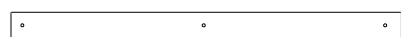

M8 | WALL RAIL - W4L07145
(x2) | 5/8"x3 3/8"x50 7/8" (16x86x1292)

H12 | DECK BRACE - W4L13771
(x2) | 1"x3 3/8"x15 7/8" (24x86x402)



H100019 | BOLT WH
(x4) | 5/16x3 3/4

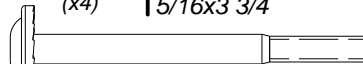

H100018 | BOLT WH
(x4) | 5/16x3 1/2

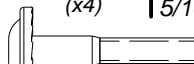

H100011 | BOLT WH
(x2) | 5/16x1 3/4

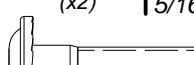

H100027 | LAG SCREW WH
(x4) | 5/16x2

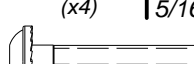

H100146 | LAG SCREW WH
(x2) | 1/4x2

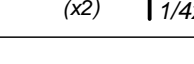

H100030 | WASHER LOCK
(x14) | EXT
8x19



H100074 | T-NUT
(x2) | 5/16



H100138 | WASHER LOCK
(x2) | EXT
6x15

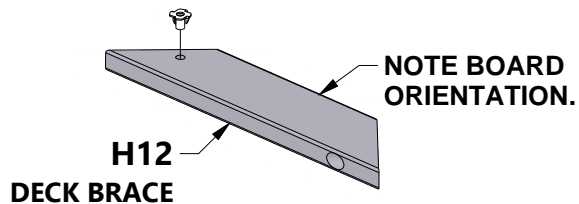
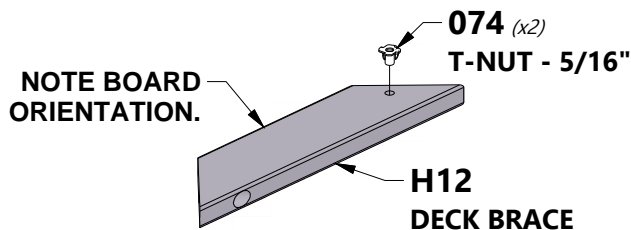

T-NUT SUB ASSEMBLY

TIP:
INSTALL T-NUTS IN WOOD FIRST

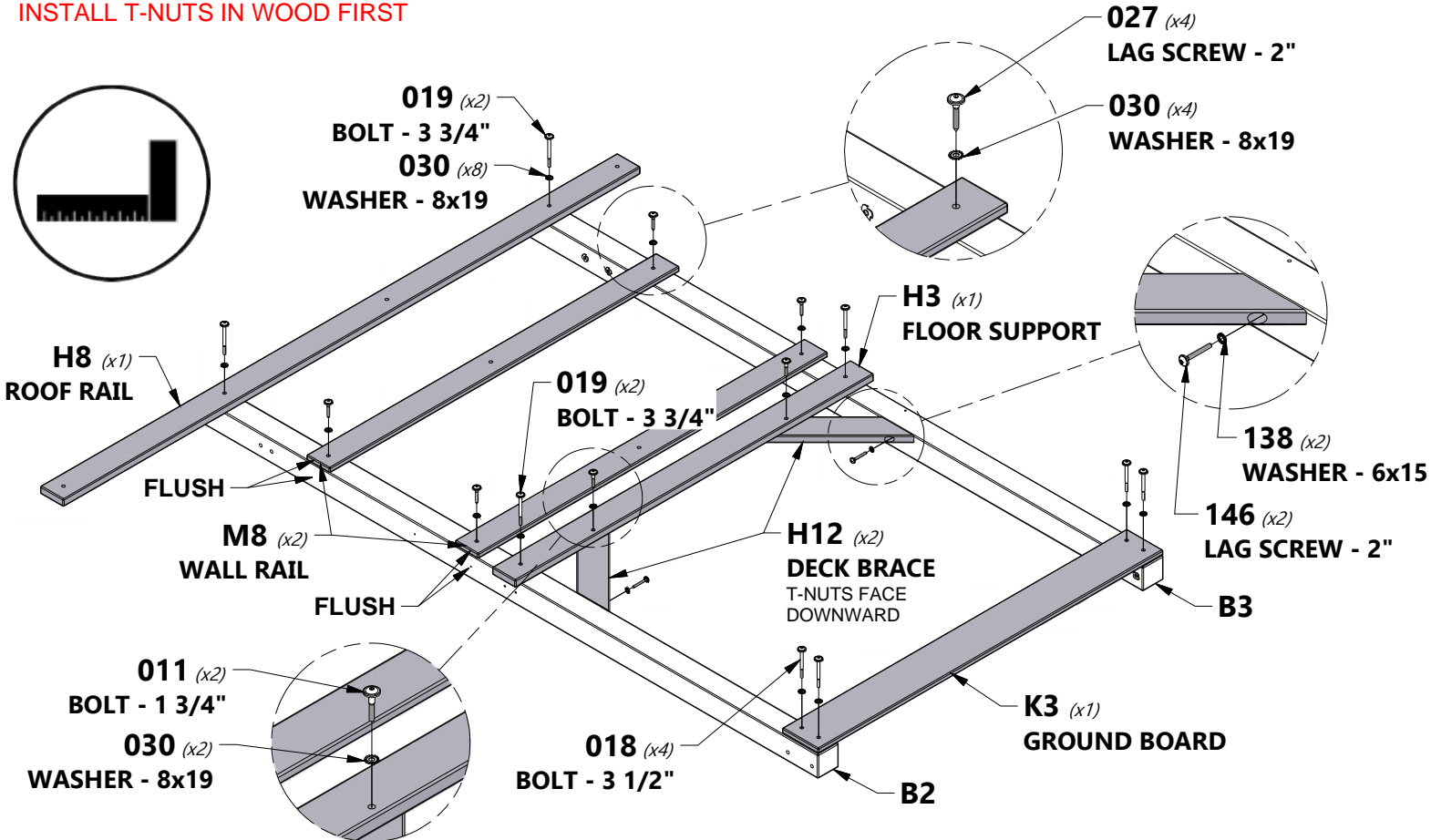



G2 | WALL RAIL - W4L07153
(x1) | 1"x5 1/4"x48 7/8" (24x134x1243)



M9 | WALL RAIL - W4L07146
(x3) | 5/8"x3 3/8"x48 7/8" (16x86x1243)

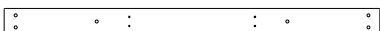

H5 | FLOOR SUPPORT - W4L07131
(x1) | 1"x3 3/8"x48 7/8" (24x86x1243)



K2 | GROUND BOARD - W4L07123
(x1) | 5/8"x5 1/4"x89 3/8" (16x134x2270)



H100019 | BOLT WH
(x4) | 5/16x3 3/4

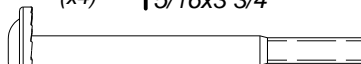

H100018 | BOLT WH
(x4) | 5/16x3 1/2

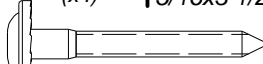

H100028 | LAG SCREW WH
(x4) | 5/16x2 1/2

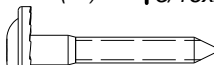

H100027 | LAG SCREW WH
(x6) | 5/16x2



H100030 | WASHER LOCK
(x18) | EXT
8x19



H100074 | T-NUT
(x4) | 5/16

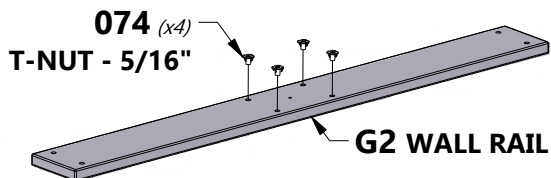

T-NUT SUB ASSEMBLY

TIP:
INSTALL T-NUTS IN WOOD FIRST

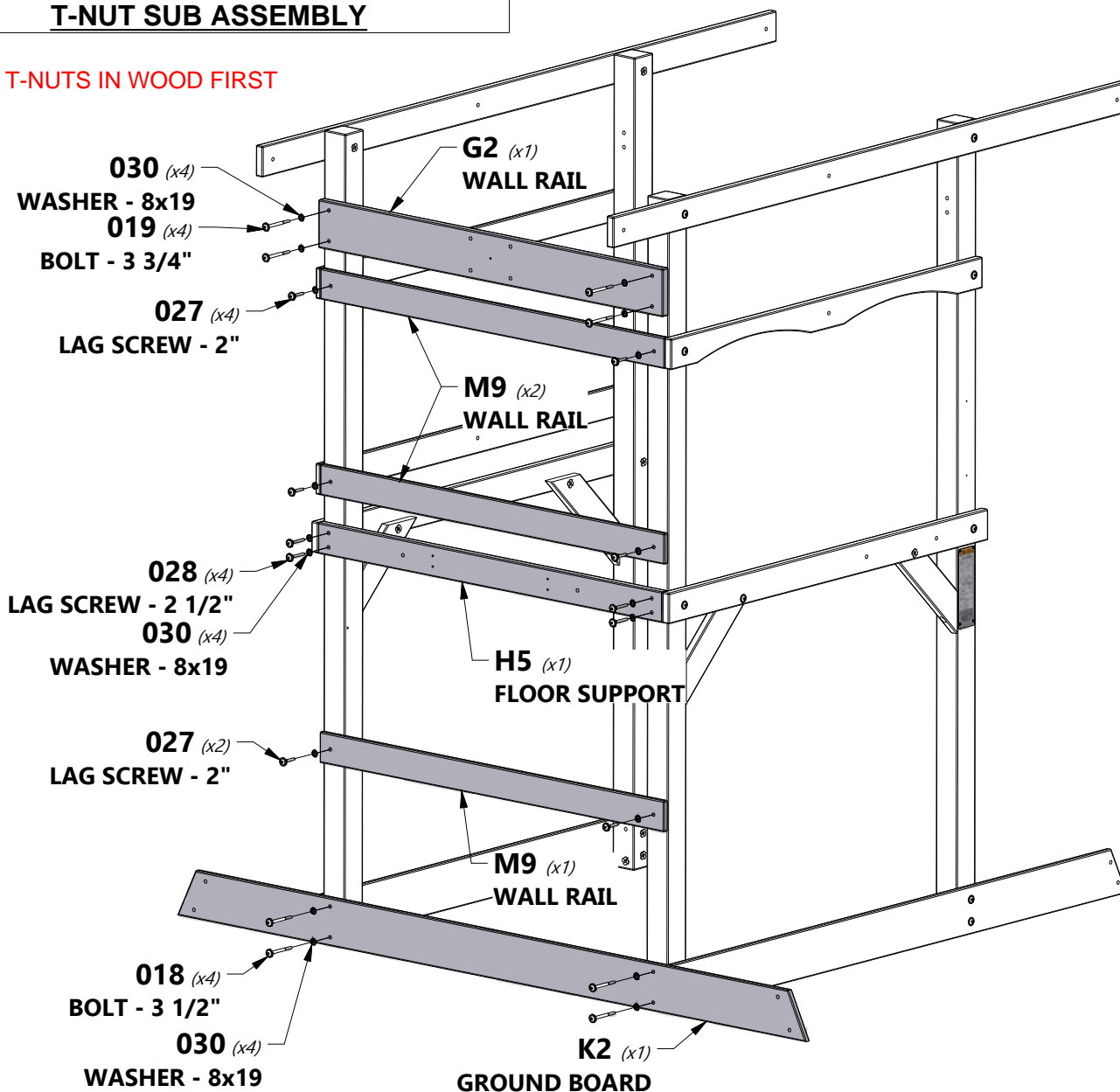



G1 | GROUND BOARD - W4L13582
(x1) | 1"x5 1/4"x79 1/8" (24x134x2010)

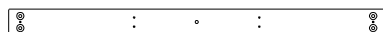

H4 | FLOOR SUPPORT - W4L07130
(x1) | 1"x3 3/8"x48 7/8" (24x86x1243)

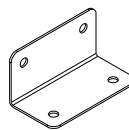

A100140 | L BRACKET 66x66x127
(x1)



W1 | SUPPORT BOARD - W4L07156
(x1) | 2"x3 3/8"x78 7/8" (50x86x2005)

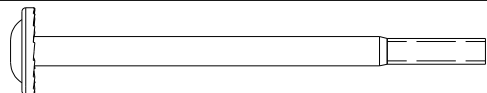

H100505 | BOLT WH
(x4) | 5/16x4 3/4

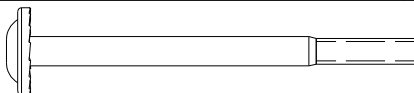

H100020 | BOLT WH
(x2) | 5/16x4

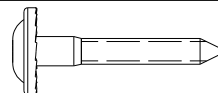

H100027 | LAG SCREW WH
(x4) | 5/16x2



H100030 | WASHER LOCK
EXT
(x10) | 8x19

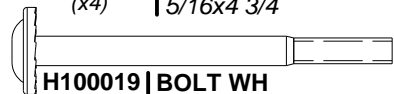

H100019 | BOLT WH
(x2) | 5/16x3 3/4

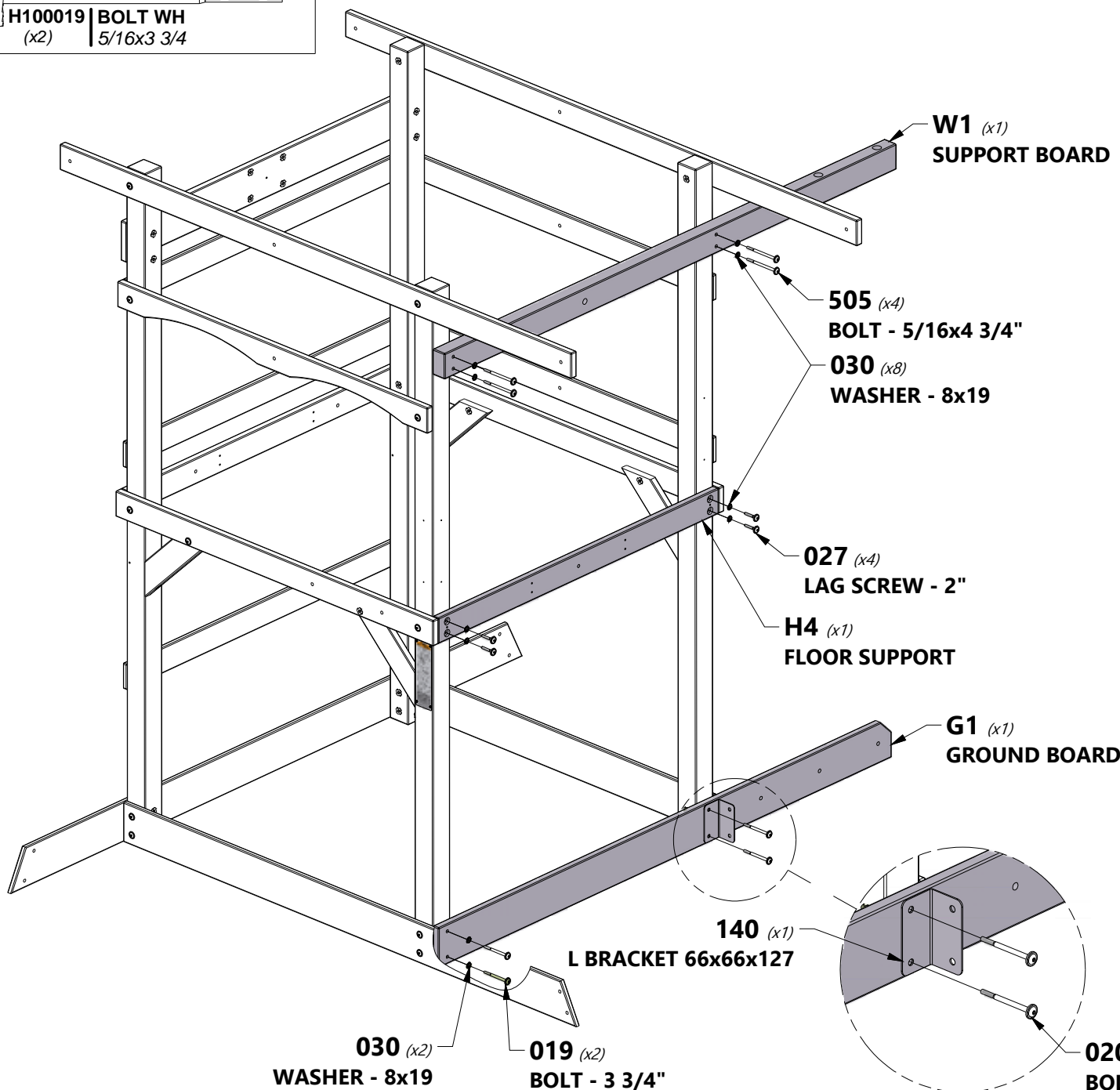



K4 | GROUND BOARD - W4L13756
(x1) | 5/8"x5 1/4"x23 1/8" (16x134x588)



H100115 | BOLT WH
(x2) | 5/16x1/2



H100031 | WASHER LOCK
(2) | EXT
12x19



H100004 | NUT BARREL WH
(x2) | 5/16 x 5/8

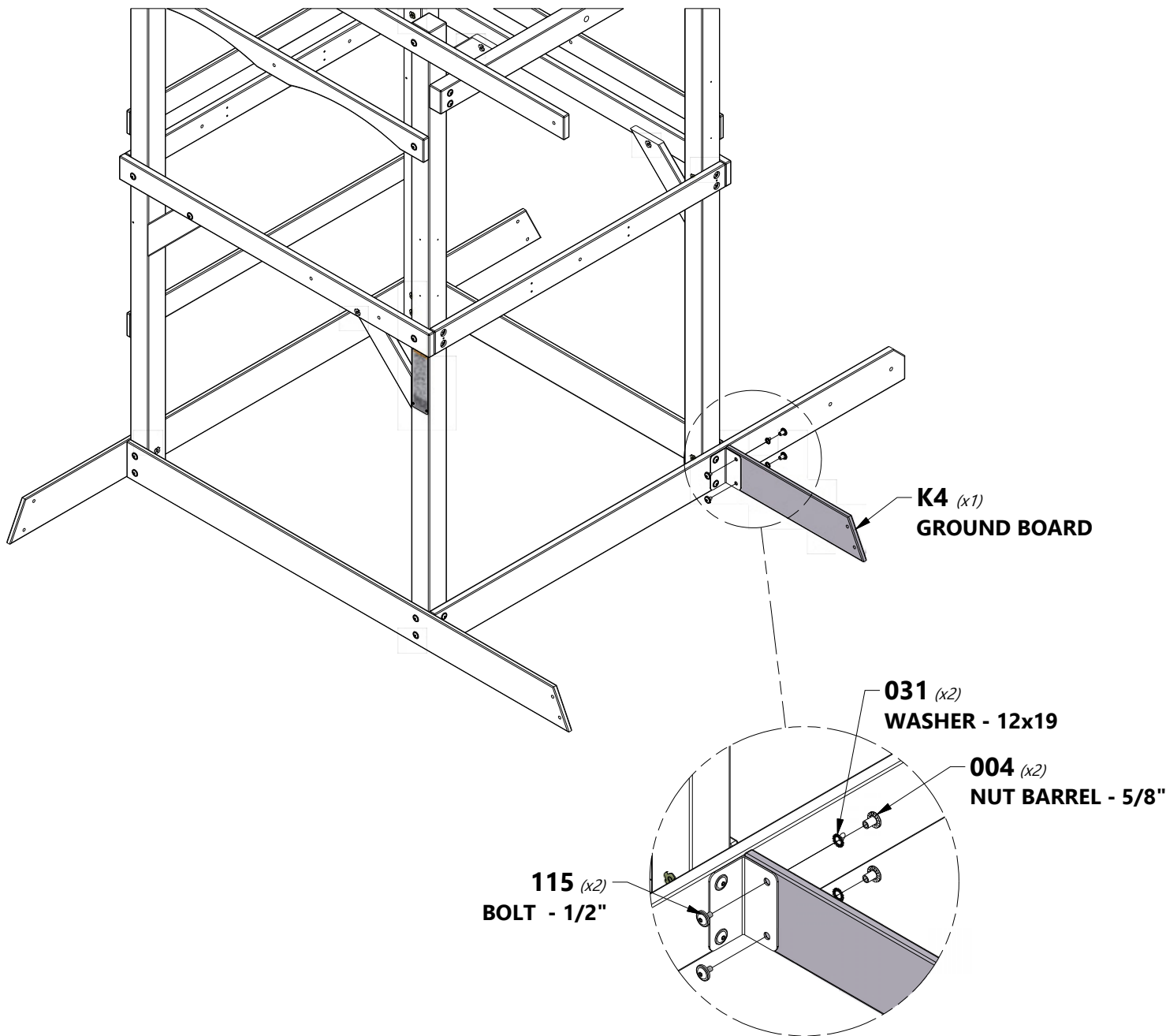



H1 | **ANGLE BRACE - W4L07127**
 (x2) | 1"x3 3/8"x44 1/2" (24x86x1129)

H11 | **DECK BRACE - W4L07296**
 (x2) | 1"x3 3/8"x17 3/4" (24x86x450)

H100011 | **BOLT WH**
 (x2) | 5/16x1 3/4



H100030 | **WASHER LOCK**
 (6) | **EXT**
 8x19

H100010 | **BOLT WH**
 (x4) | 5/16x1-1/2

H100138 | **WASHER LOCK**
 (4) | **EXT**
 6x15



H100146 | **LAG SCREW WH**
 (x4) | 1/4x2

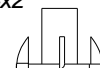

H100074 | **T-NUT**
 (x6) | 5/16

TIP:
 INSTALL T-NUTS IN WOOD FIRST

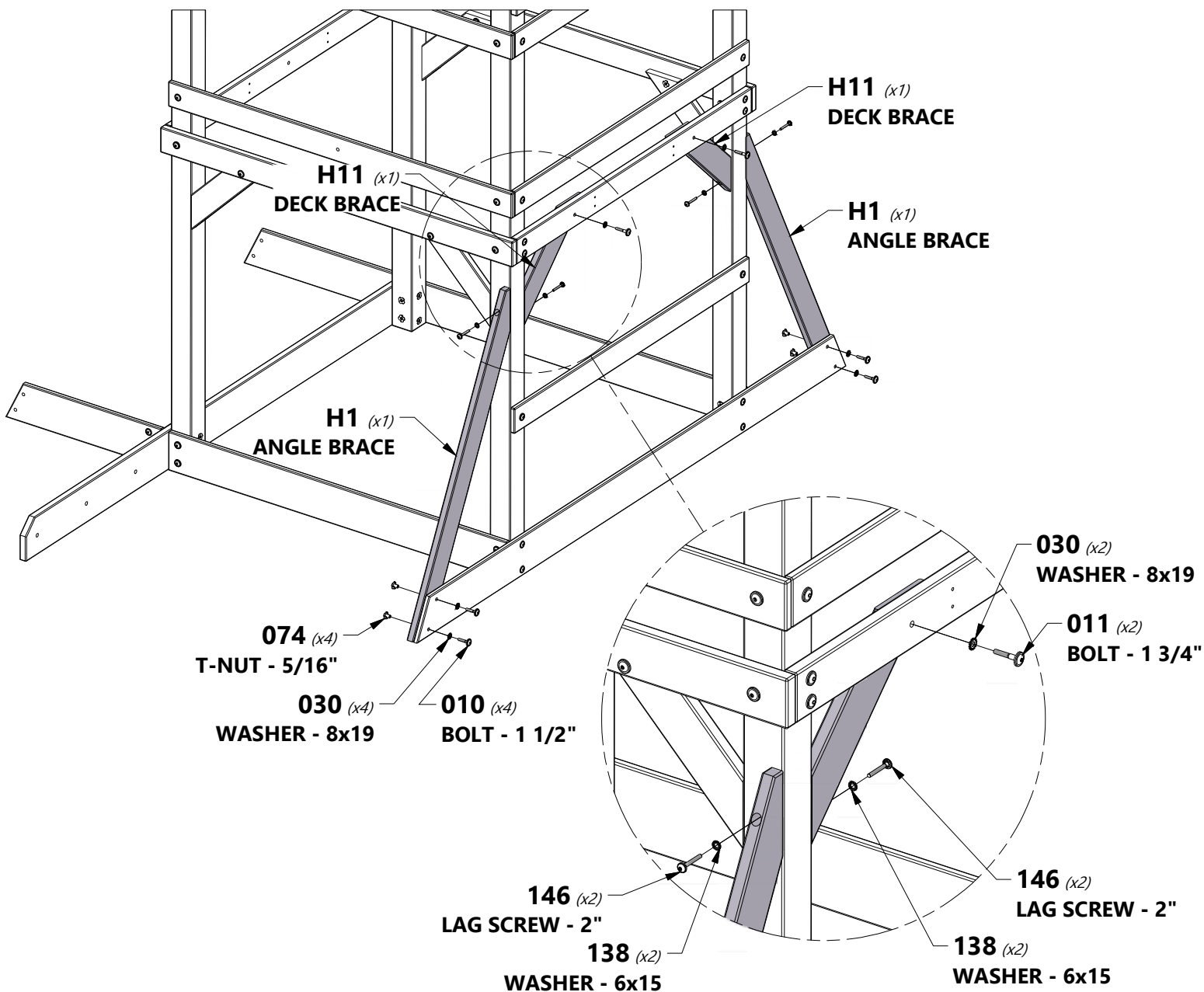
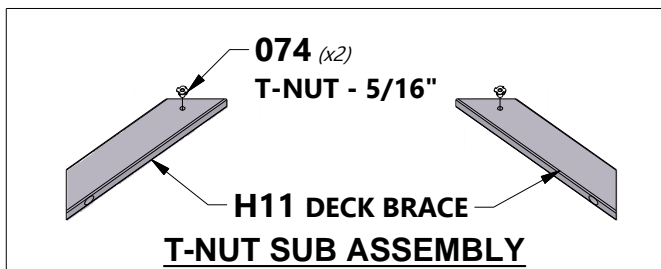

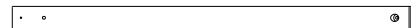

E1 RAIL - W4L13761
(x1) 1 3/8"x3"x51 7/8" (36x76x1318)



E3 RAIL - W4L13762
(x1) 1 3/8"x3"x51 7/8" (36x76x1318)



E2 RAIL - W4L13755
(x1) 1 3/8"x3"x51 7/8" (36x76x1318)

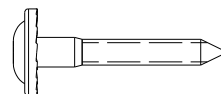

H100027 LAG SCREW WH
(x6) 5/16x2



H100030 WASHER LOCK
(x7) EXT
8x19

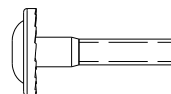

H100010 BOLT WH
(x1) 5/16x1-1/2



H100074 T-NUT
(x4) 5/16

TIP:
INSTALL T-NUTS IN WOOD FIRST

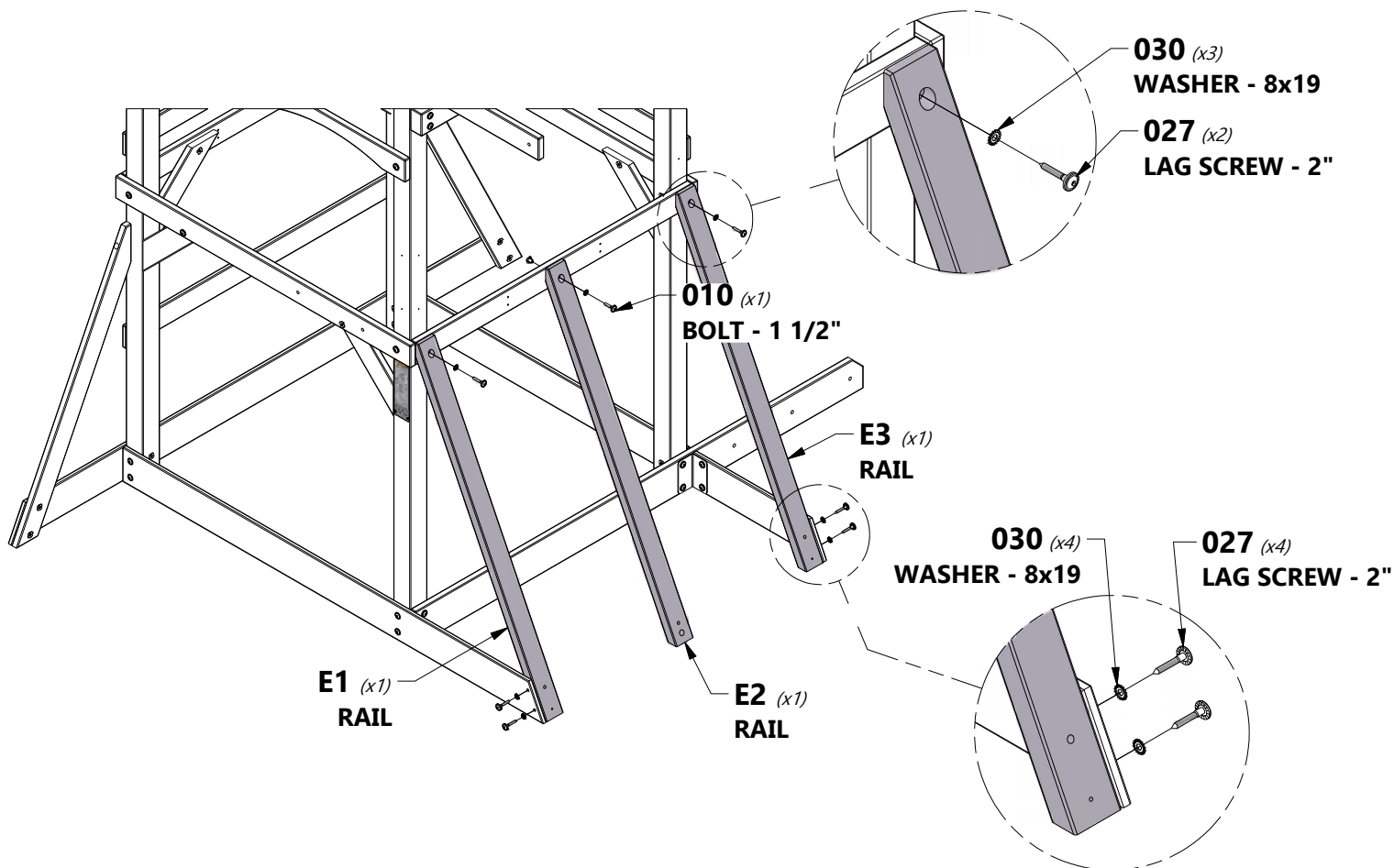
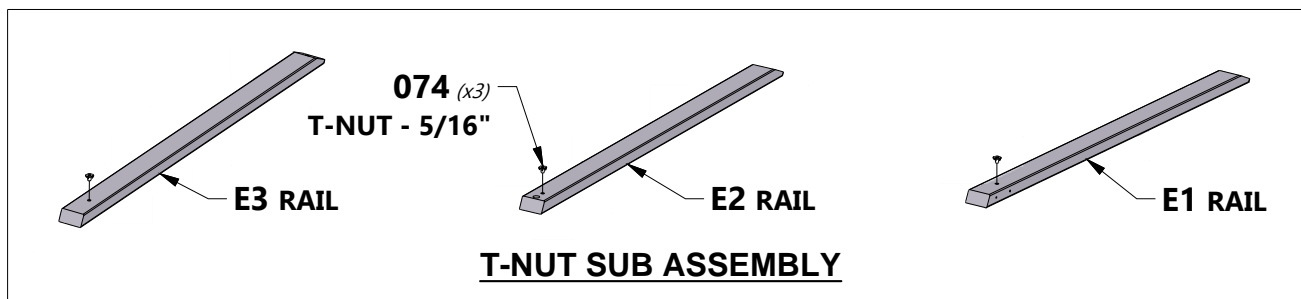

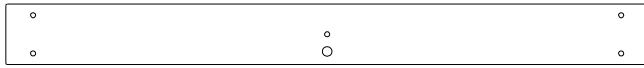
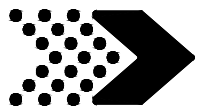

K5 | GROUND BOARD - W4L13757
(x1) | 5/8"x4 3/4"x50 1/4" (16x120x1275)

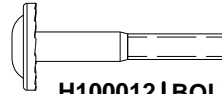

H100012 | BOLT WH
(x3) | 5/16x2



H100030 | WASHER LOCK
(x5) | EXT
8x19

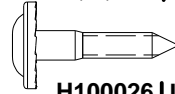

H100026 | LAG SCREW WH
(x2) | 5/16x1 1/2

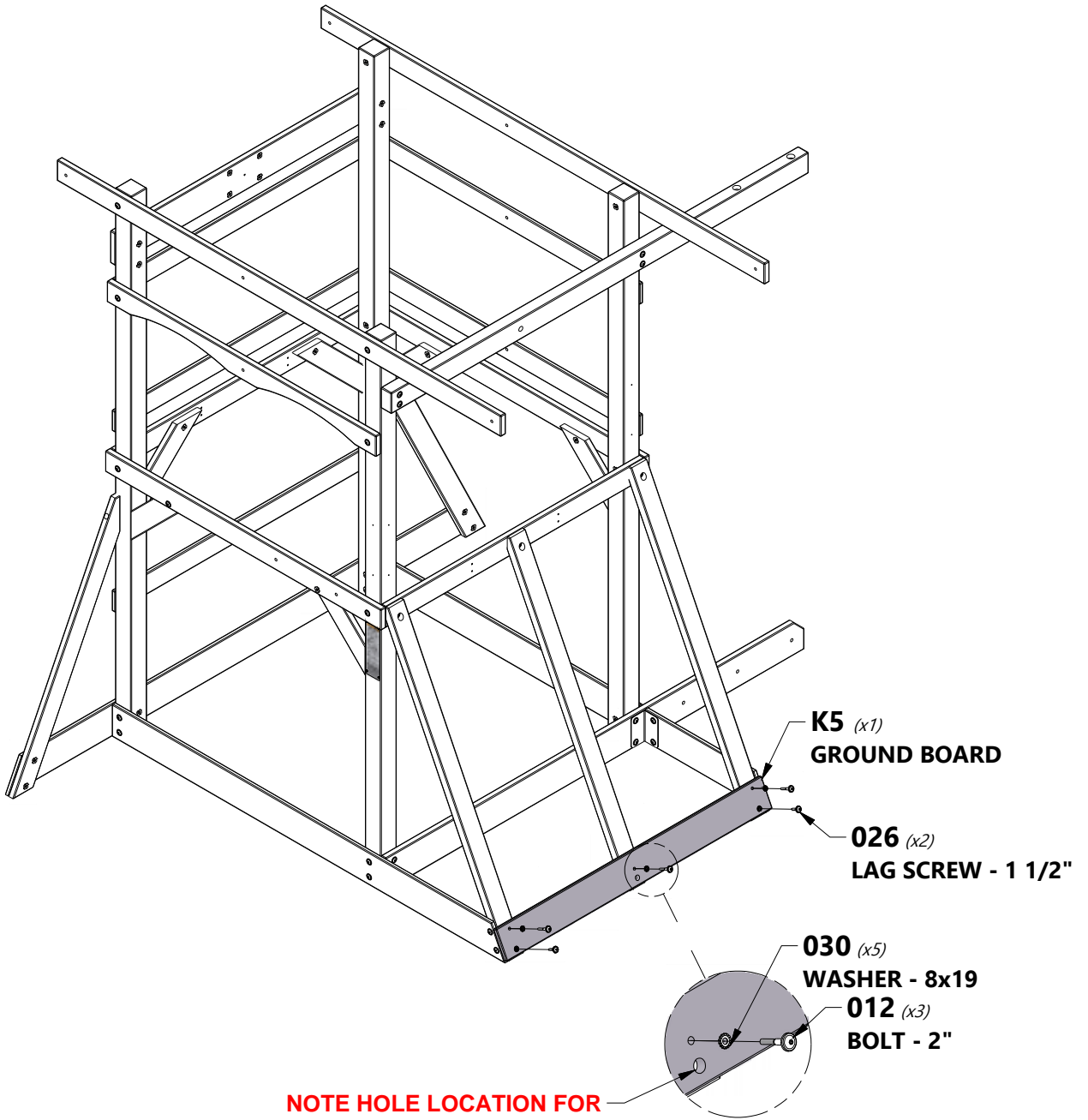

K5 (x1)
GROUND BOARD

026 (x2)
LAG SCREW - 1 1/2"

030 (x5)
WASHER - 8x19

012 (x3)
BOLT - 2"

NOTE HOLE LOCATION FOR PROPER ORIENTATION OF THE BOARD.

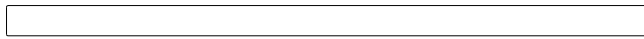
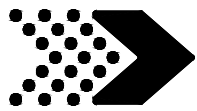

J1 | FLOOR JOIST - W4L07139
(x2) | 1"x2 3/8"x50 1/4" (24x60x1275)

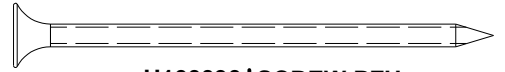

H100090 | SCREW PFH
(x8) | 8x2 1/2"

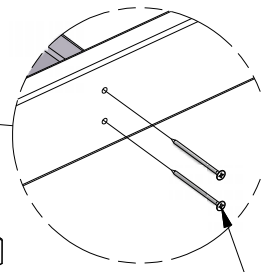
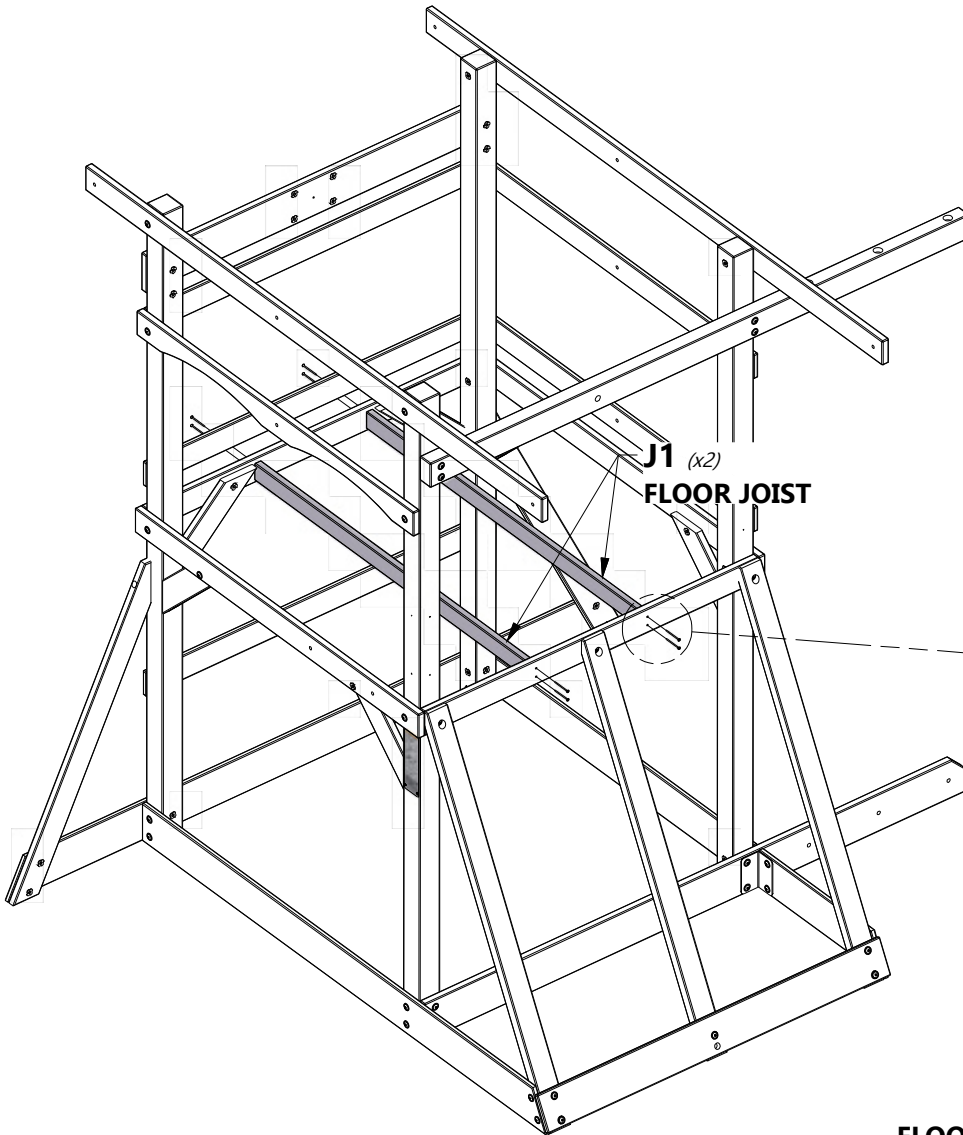

090 (x8)
SCREW - 2 1/2"

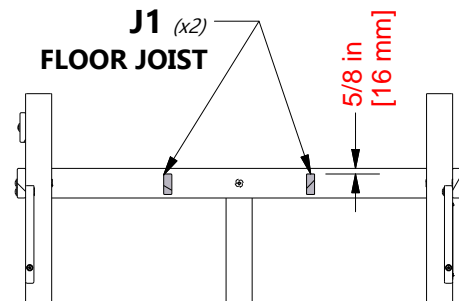



M2 | ROCK WALL BOARD - W4L13759
(x3) | 5/8"x3 3/8"x48 7/8" (16x86x1243)

M3 | ROCK WALL BOARD - W4L13760
(x3) | 5/8"x3 3/8"x48 7/8" (16x86x1243)

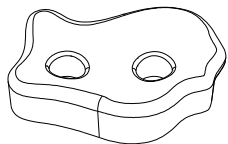

A6P00037 | GREEN HC ROCK #2
(x9)

H100063 | BOLT PTH
(x18) | 1/4x3/4

H100108 | WASHER LOCK INT
(x18) | 8x15

H100072 | T-NUT
(x18) | 1/4

TIP:
INSTALL T-NUTS IN WOOD FIRST

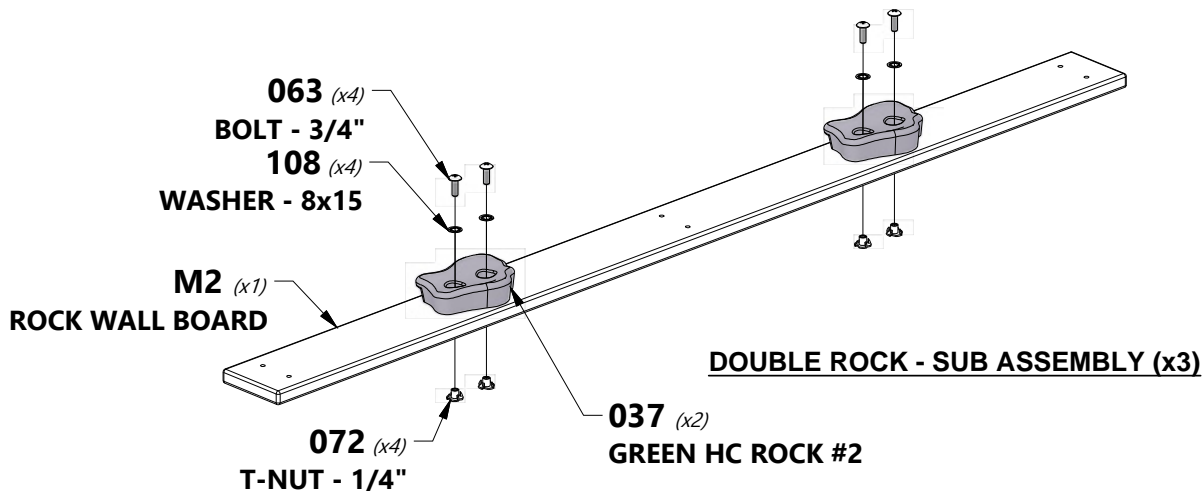
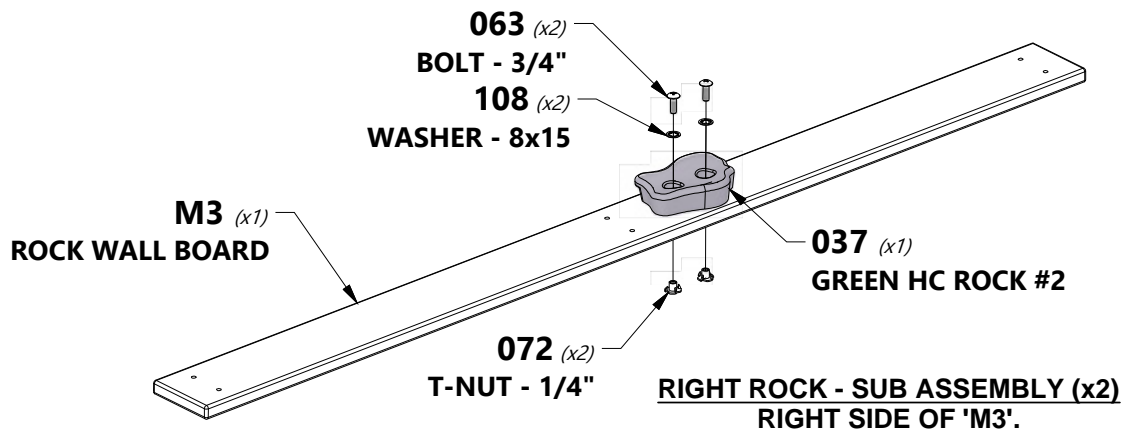
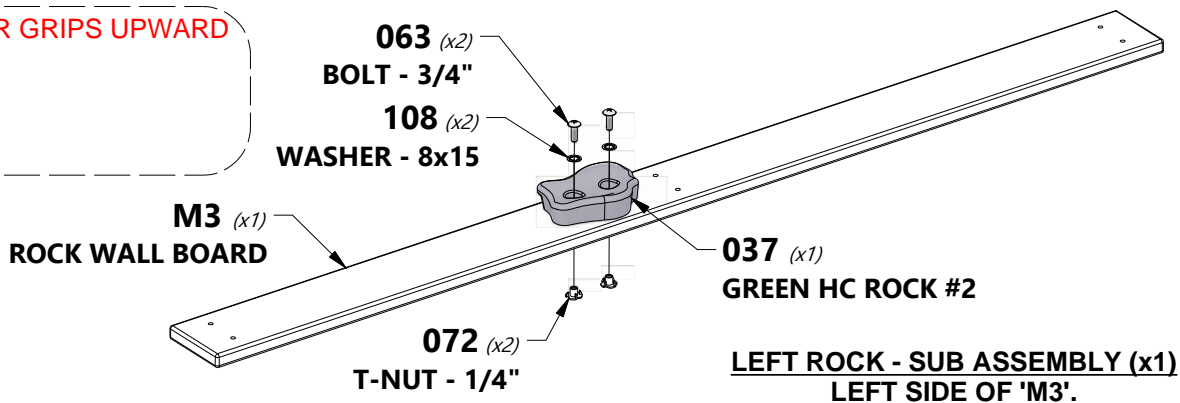
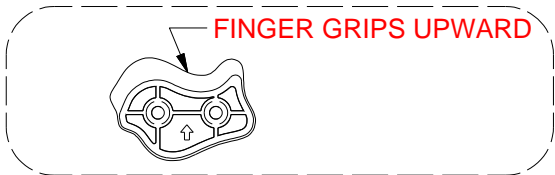



M1 | ROCK WALL BOARD - W4L13758
(x7) | 5/8"x3 3/8"x48 7/8" (16x86x1243)

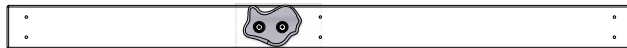

LEFT ROCK - SUB ASSEMBLY (x1)
(FROM STEP 14).

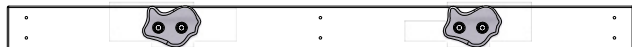

DOUBLE ROCK - SUB ASSEMBLY (x3)
(FROM STEP 14).



RIGHT ROCK - SUB ASSEMBLY (x2)
(FROM STEP 14).



H100086 | SCREW PFH
(x78) | 8x1 1/2

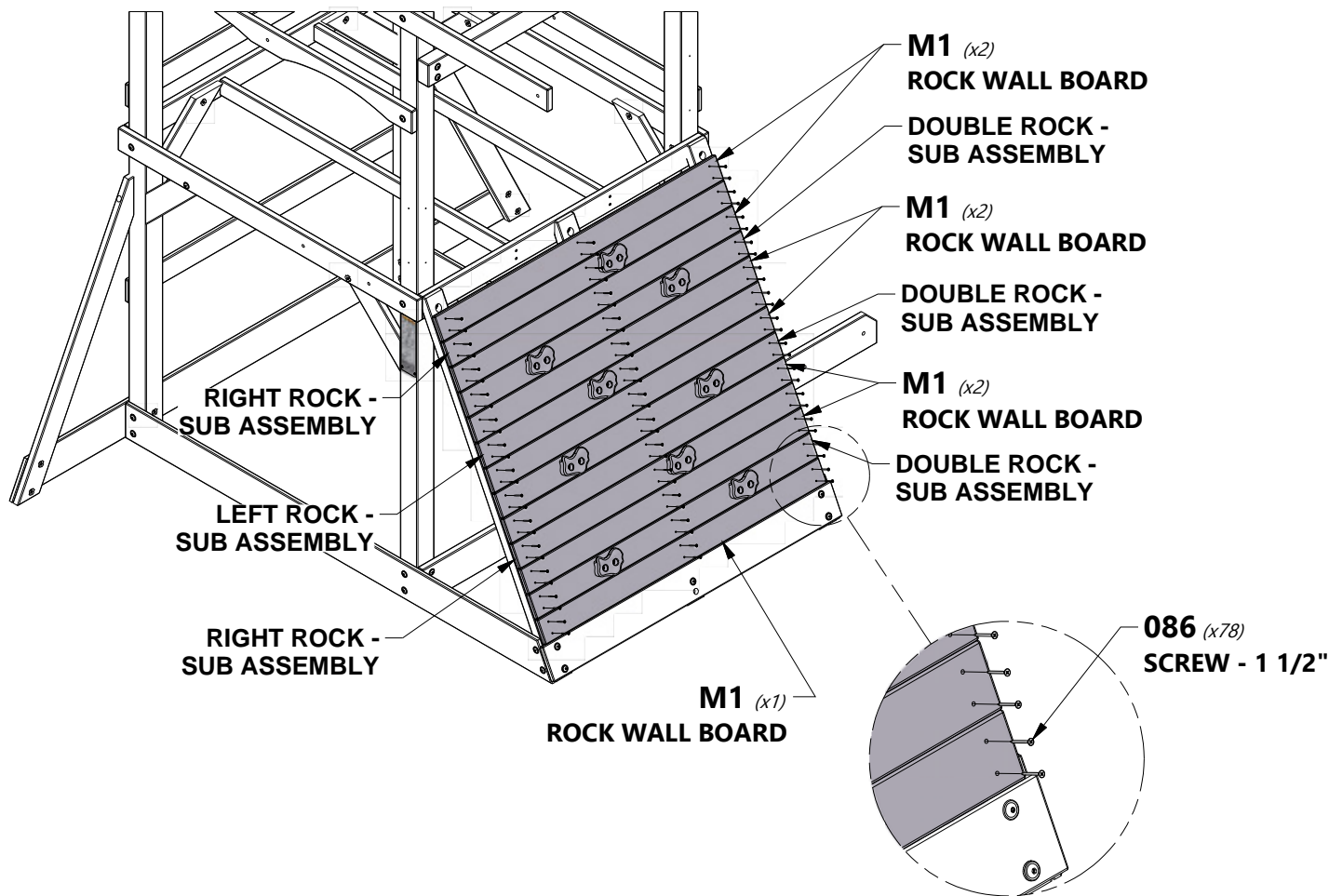

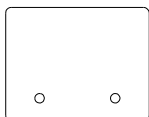

J2 | FLOOR SUPPORT - W4L06710
(x4) | 1"x2 3/8"x3" (24x60x76)

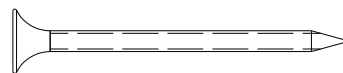

H100089 | SCREW PFH
(x8) | 8x1 3/4

5/8 in
[16 mm]

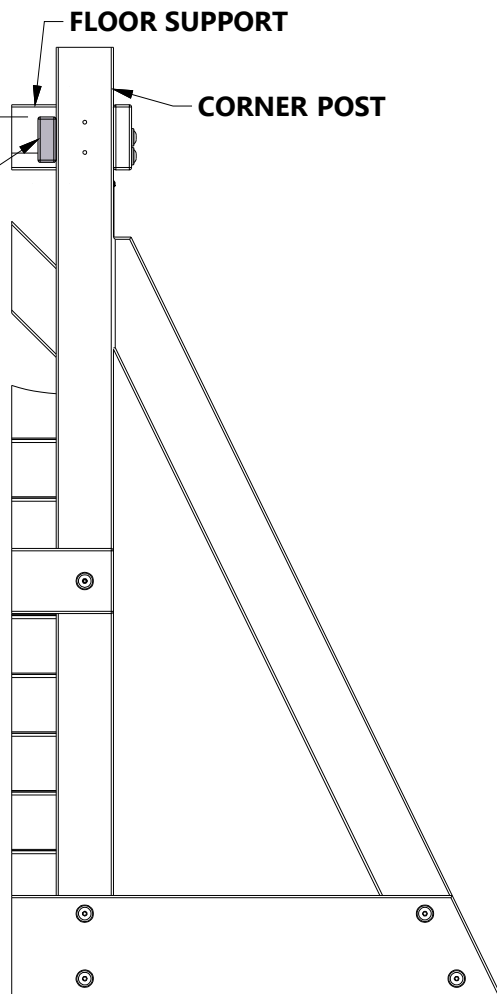
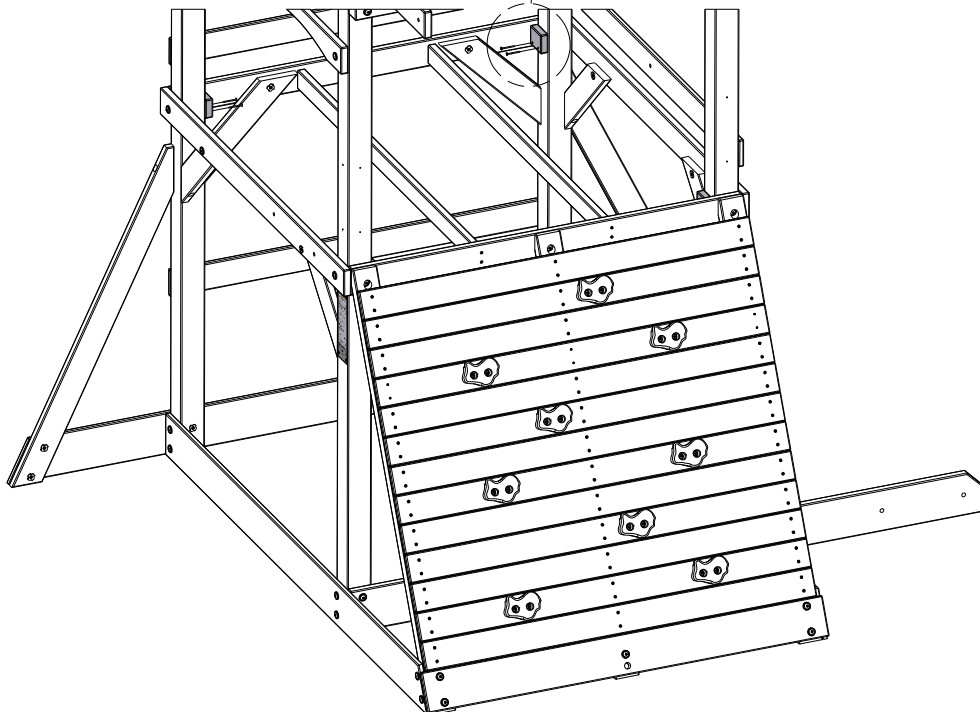
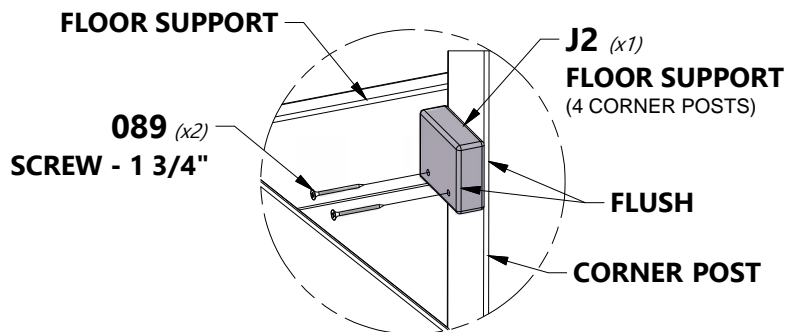
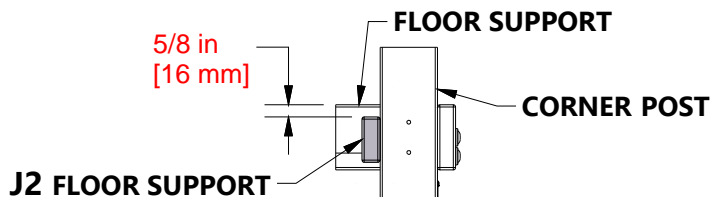

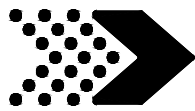

T1 | SUPPORT BOARD - W4L07140
(x2) | 1"x1 3/8"x44 1/8" (24x34x1122)

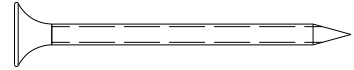

H100089 | SCREW PFH
(x10) | 8x1 3/4

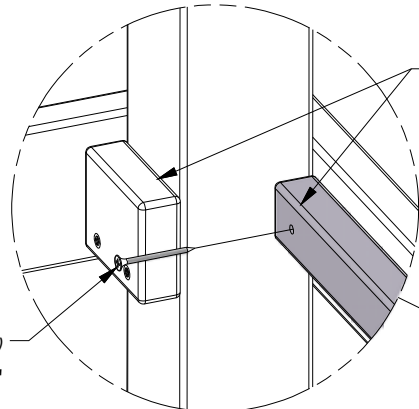

FLUSH

089 (x10)
SCREW - 1 3/4"

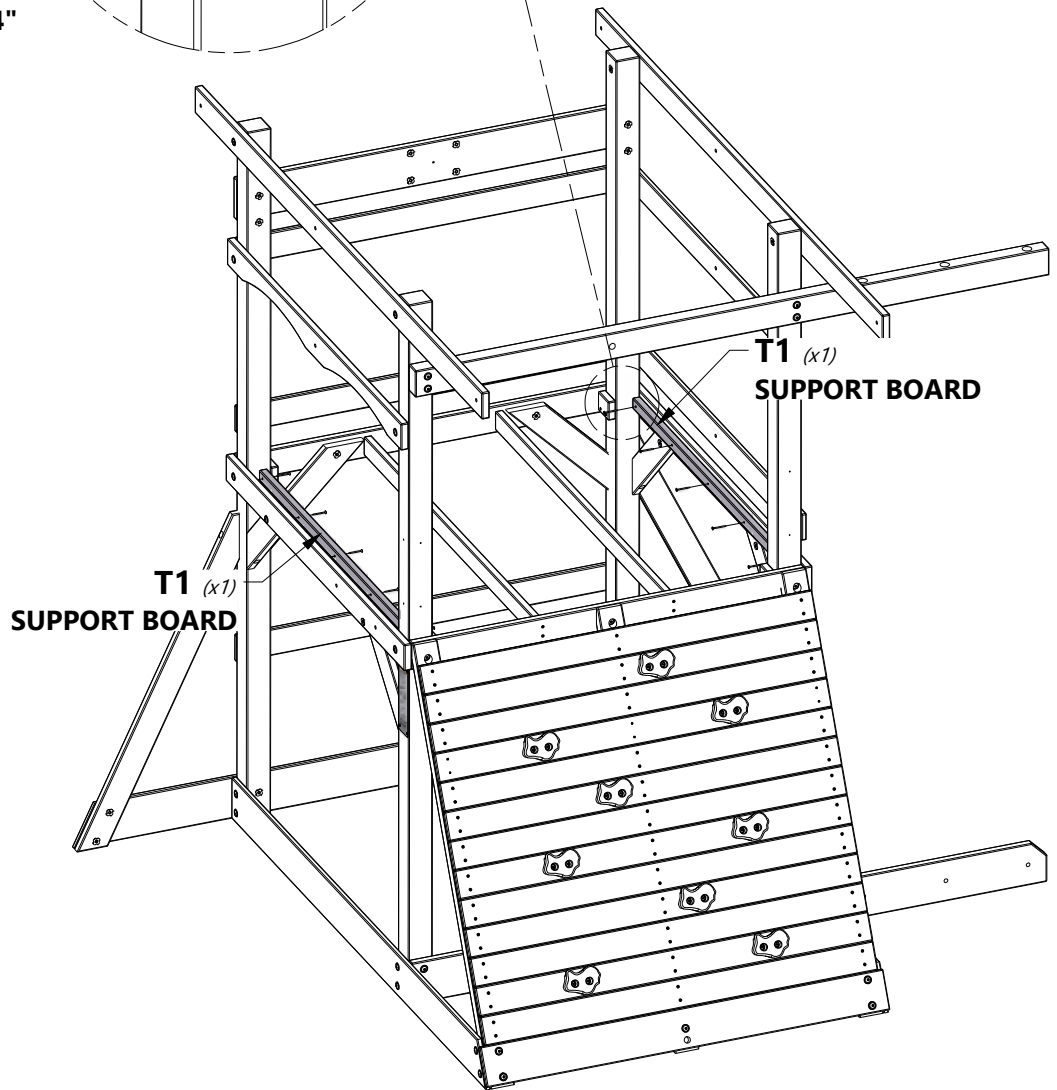

T1 (x1)
SUPPORT BOARD

T1 (x1)
SUPPORT BOARD

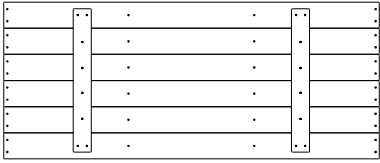
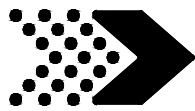

FP1 | FLOOR PANEL
(x2) | 1 1/4"x17"x48 5/8" (32x432x1242)



M4 | FLOOR BOARD - W4L07141
(x2) | 5/8"x3"x42 7/8" (16x76x1090)



M5 | FLOOR BOARD - W4L07142
(x1) | 5/8"x3 3/8"x48 7/8" (16x86x1242)

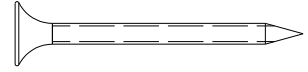

H100086 | SCREW PFH
(x86) | 8x1 1/2

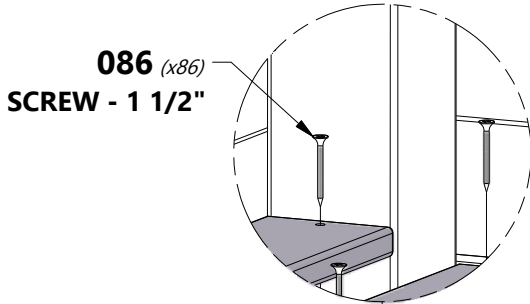

086 (x86)
SCREW - 1 1/2"

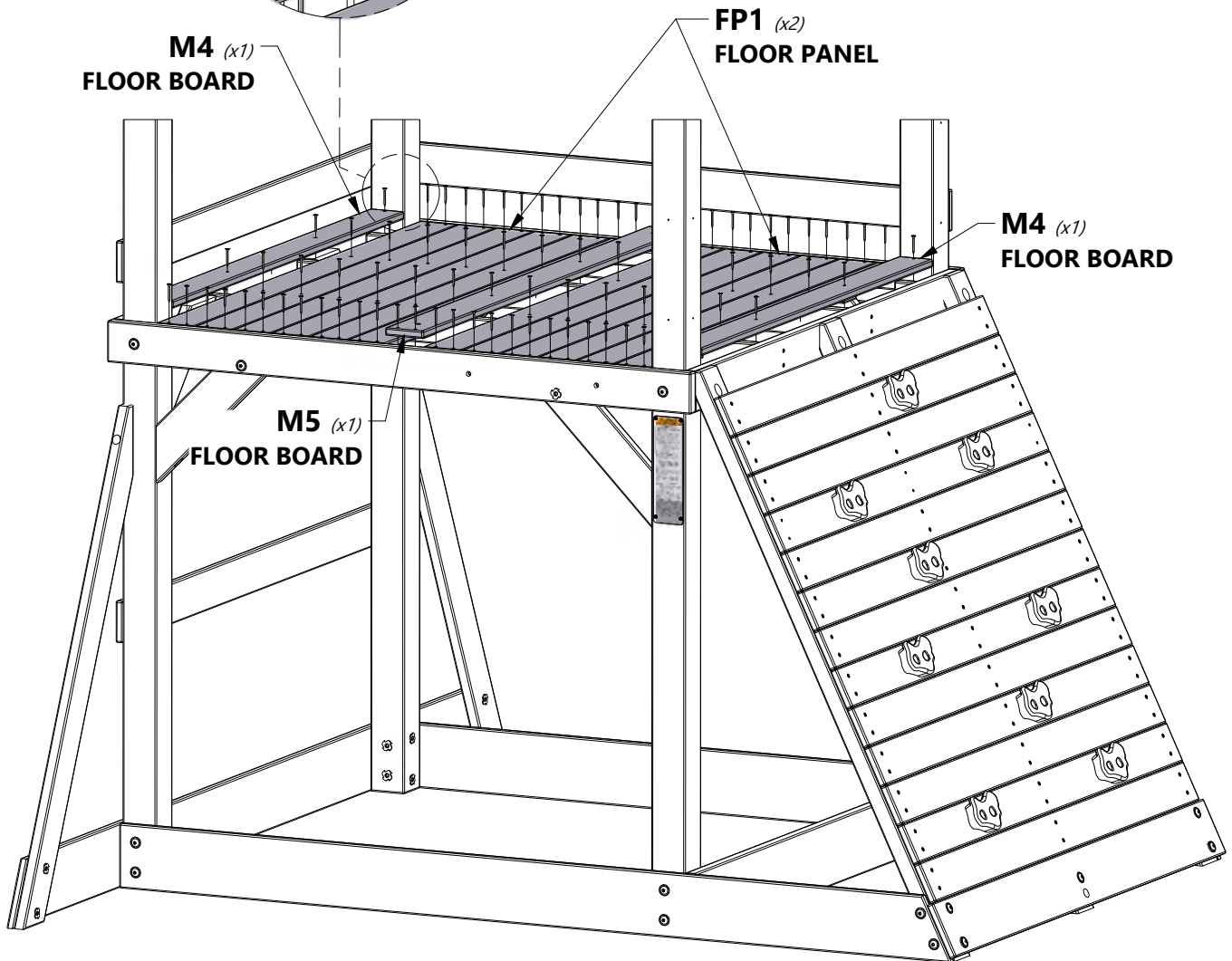

M4 (x1)
FLOOR BOARD

FP1 (x2)
FLOOR PANEL

M4 (x1)
FLOOR BOARD

M5 (x1)
FLOOR BOARD

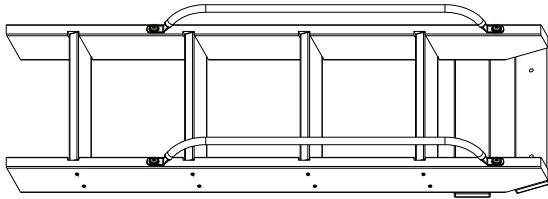
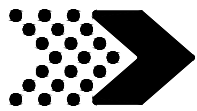

(1) LADDER ASSEMBLY

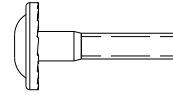

H100010 | BOLT WH
(x2) | 5/16x1-1/2



H100030 | WASHER LOCK
(x2) | EXT
8x19

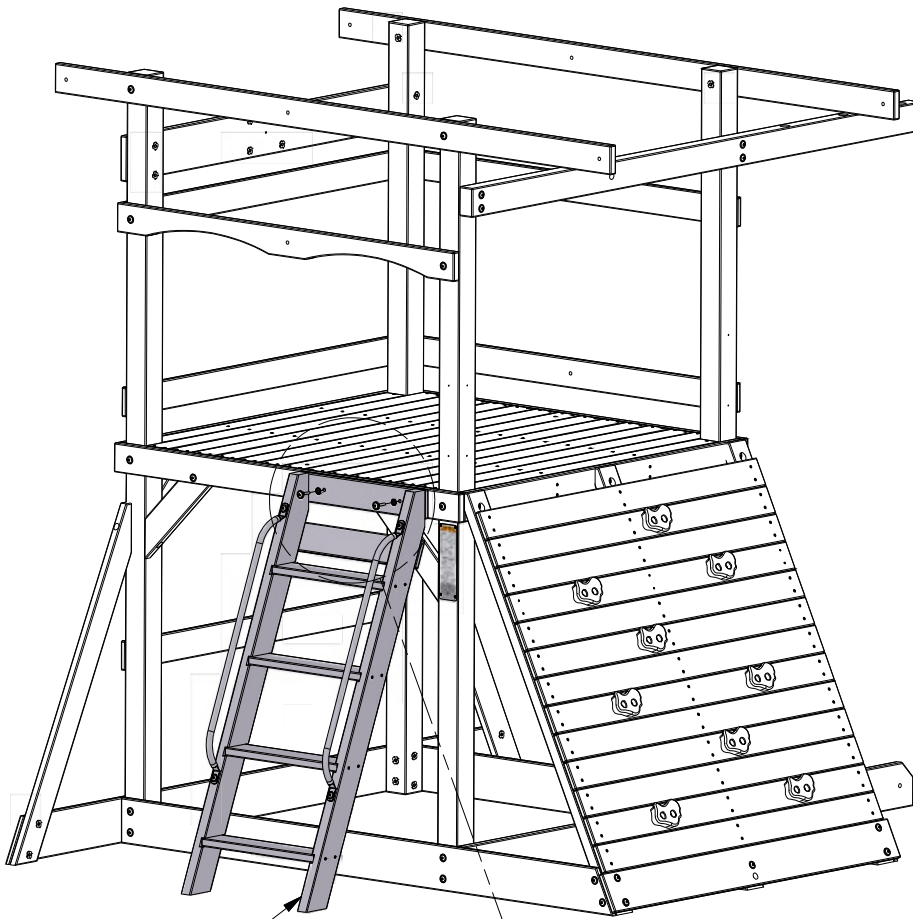

LADDER ASSEMBLY

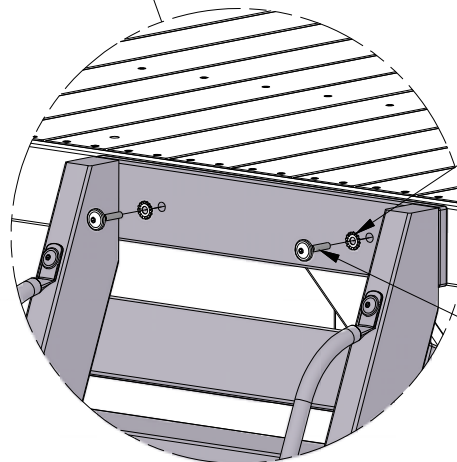

030 (x2)
WASHER - 8x19

010 (x2)
BOLT - 1 1/2"



H6 | UPRIGHT - W4L13763
(x1) | 1"x3 3/8"x72" (24x86x1828)



H100011 | BOLT WH
(x1) | 5/16x1 3/4

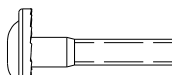

H100010 | BOLT WH
(x2) | 5/16x1-1/2



H100074 | T-NUT
(x3) | 5/16



H100030 | WASHER LOCK
(x3) | EXT
8x19

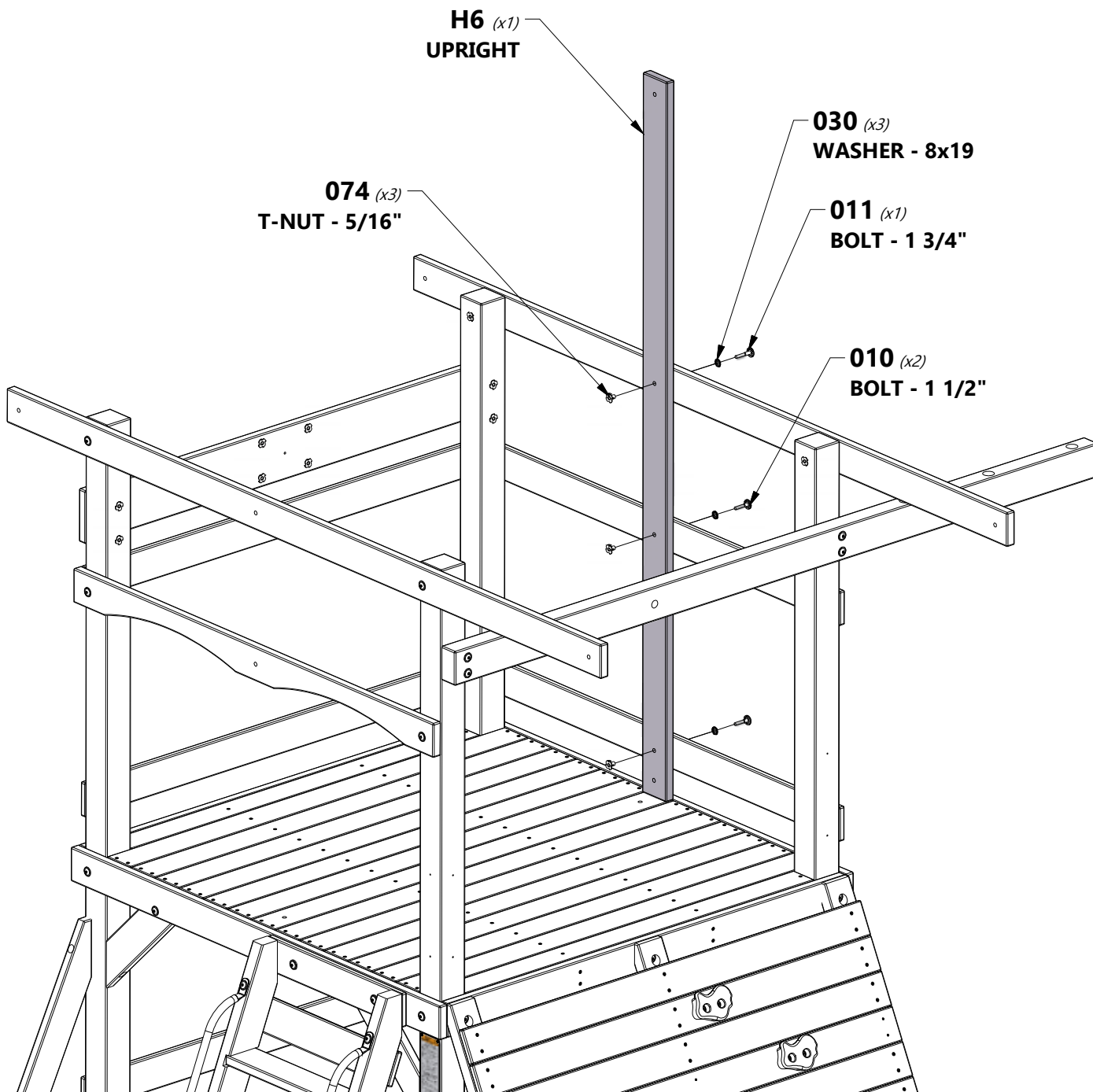

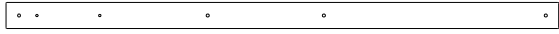
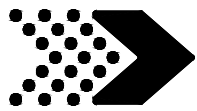

H7 | UPRIGHT - W4L13764
(x1) | 1"x3 3/8"x72" (24x86x1828)

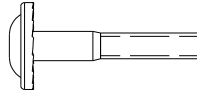

H100011 | BOLT WH
(x2) | 5/16x1 3/4



H100030 | WASHER LOCK
(x2) | EXT
8x19



H100074 | T-NUT
(x2) | 5/16

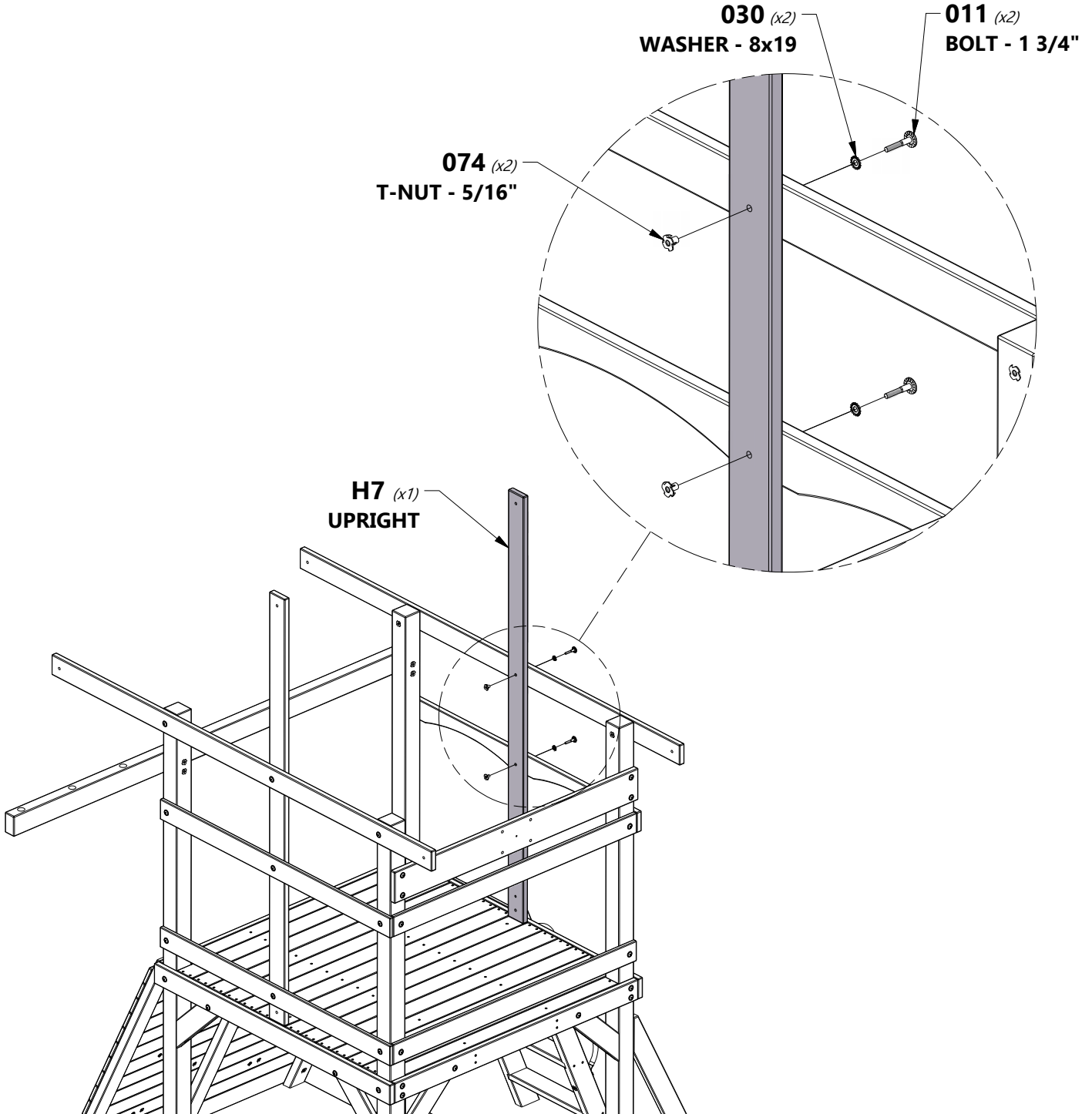

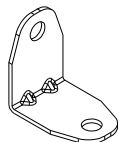

A4M01046 | L BRACKET
(2) | 2.5x38x55x55



H100115 | BOLT WH
(x2) | 5/16x1/2



H100031 | WASHER LOCK EXT
(x2) | 12x19

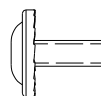

H100222 | BOLT WH
(x2) | 5/16x3/4

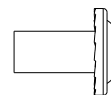

H100005 | NUT BARREL WH
(x2) | 5/16x7/8



H100074 | T-NUT
(x2) | 5/16

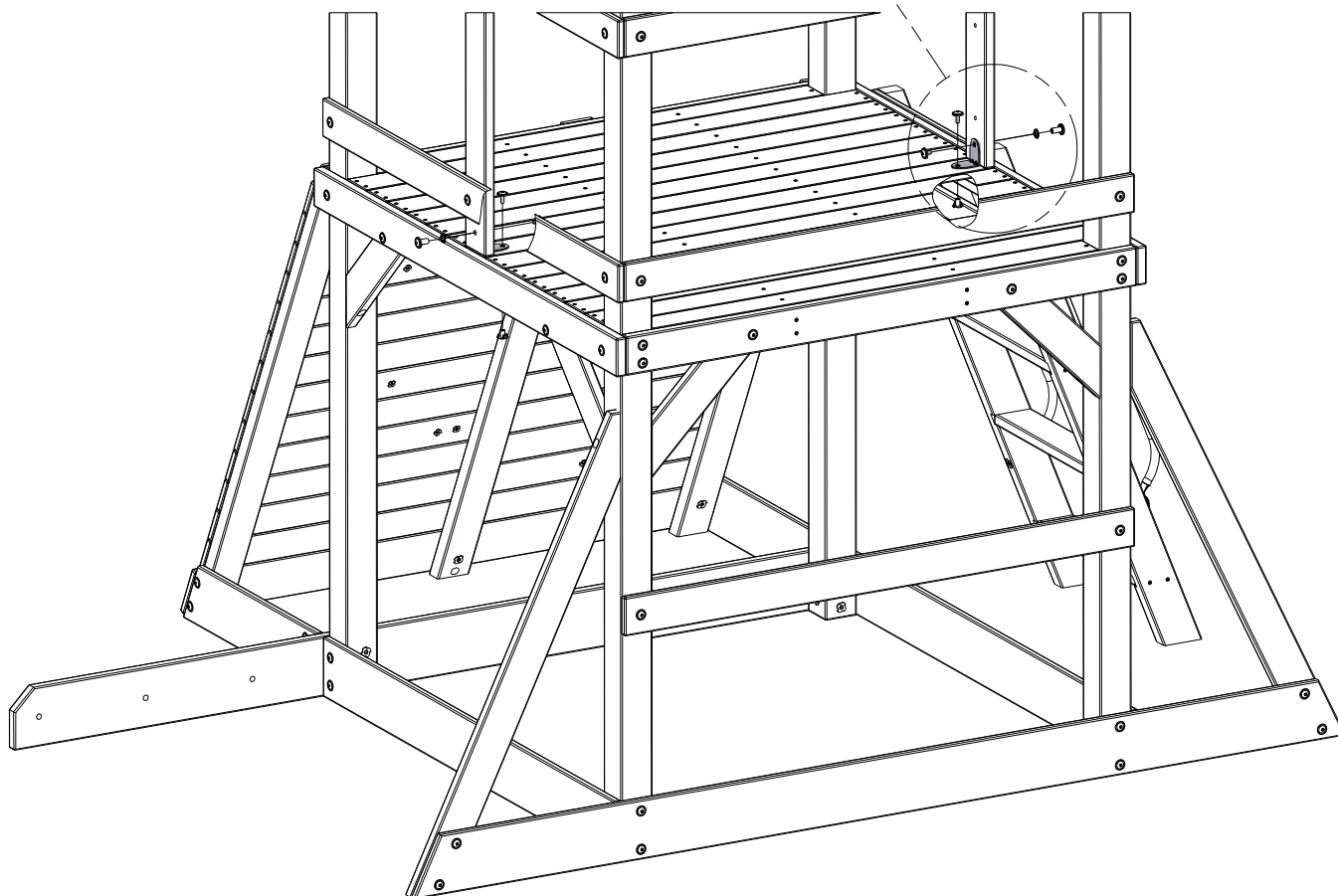
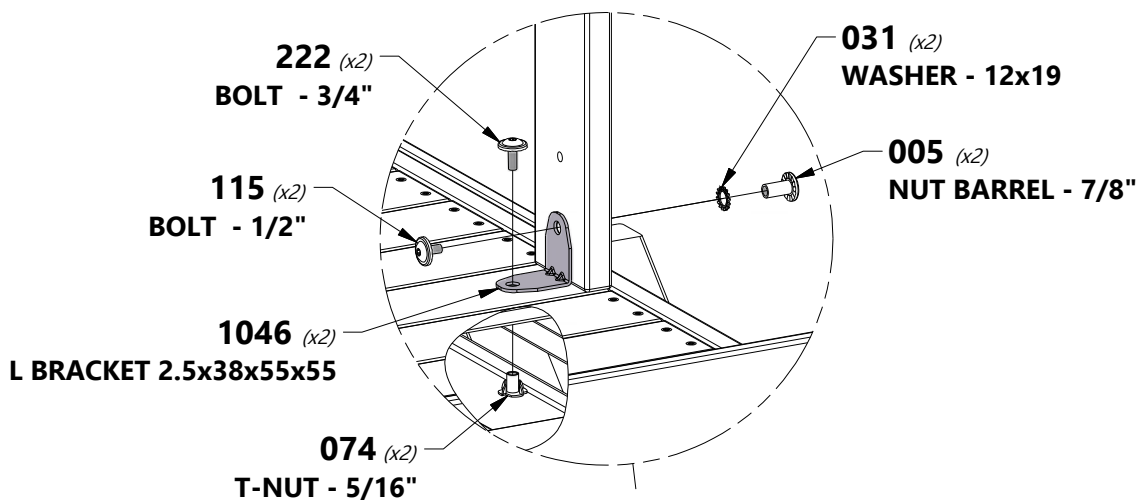

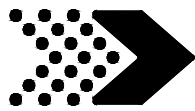

M44 PICKET - W4L07152
(x6) | 5/8"x3 3/8"x21 3/8" (16x86x542)



H100088 SCREW PFH
(x24) | 8x1 1/8

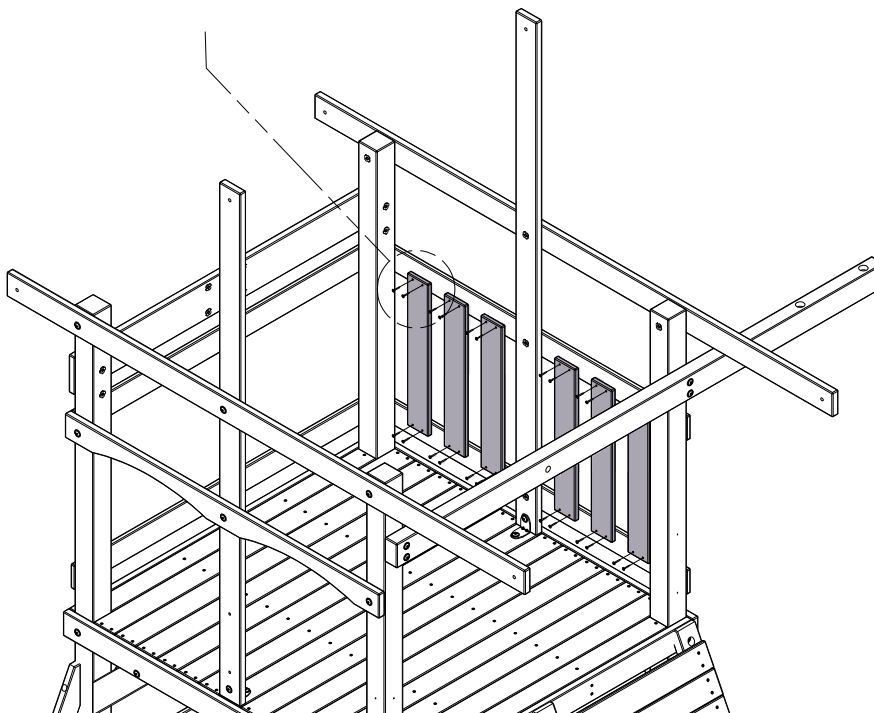
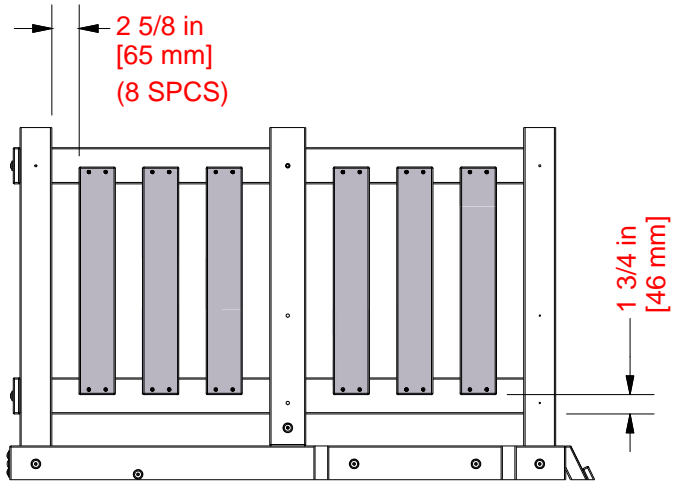
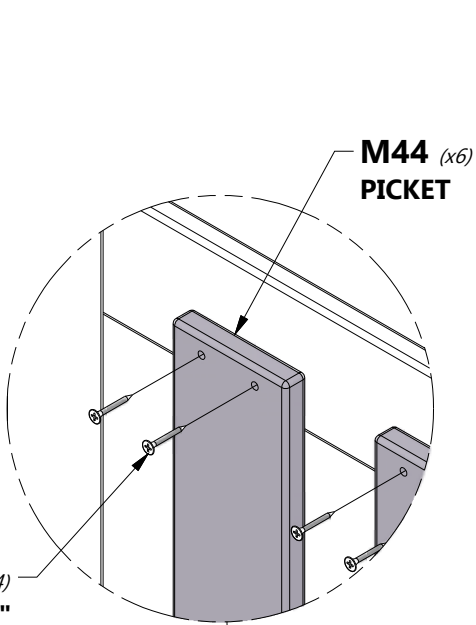

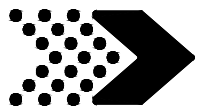

M44 PICKET - W4L07152
(x7) 5/8"x3 3/8"x2 1 3/8" (16x86x542)



H100088 SCREW PFH
(x28) 8x1 1/8

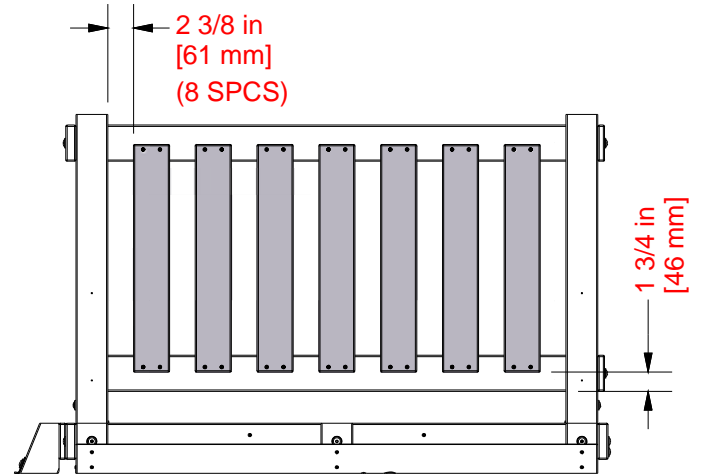

PICKET SPACING

M44 (x7)
PICKET

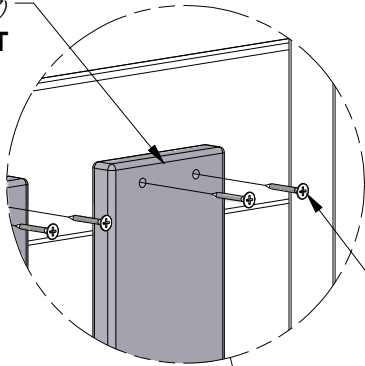

088 (x28)
SCREW - 1 1/8"

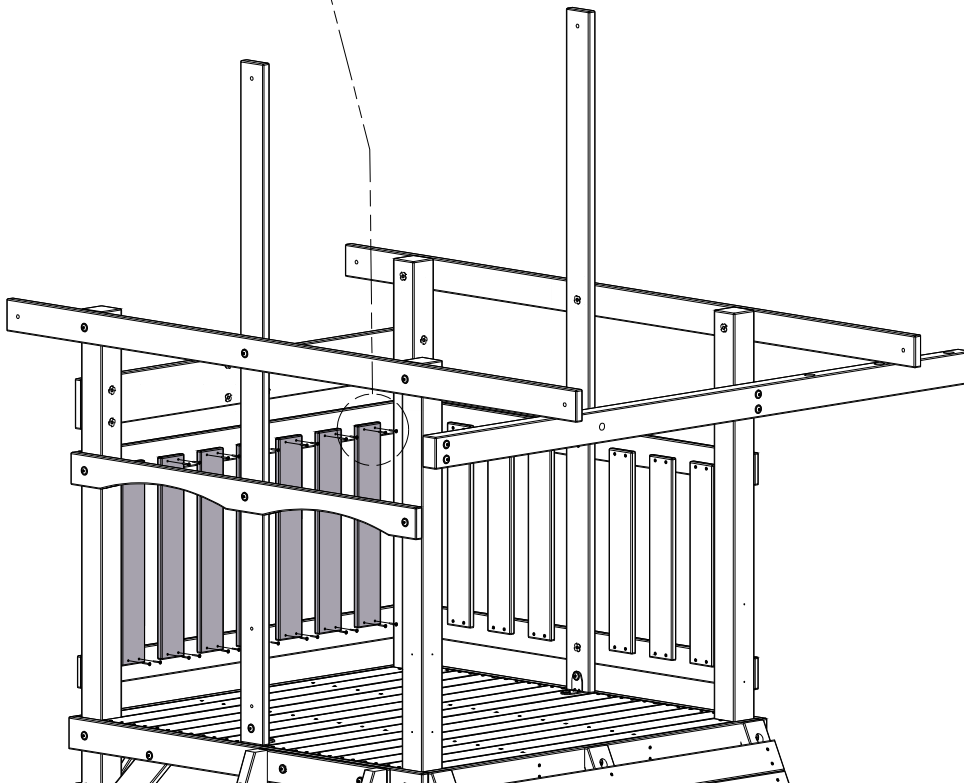



H9 | ROOF RAIL - W4L13766
(x2) | 1"x3 3/8"x50 7/8" (24x86x1291)

H10 | ROOF RAIL - W4L13767
(x1) | 1"x3 3/8"x48 7/8" (24x86x1243)



A4M01046 | L BRACKET
(x6) | 2.5x38x55x55



H100115 | BOLT WH
(x6) | 5/16x1/2

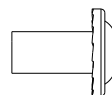

H100005 | NUT BARREL WH
(x6) | 5/16x7/8



H100074 | T-NUT
(x6) | 5/16



H100031 | WASHER LOCK
(x6) | EXT
12x19

H100008 | BOLT WH
(x6) | 5/16x1

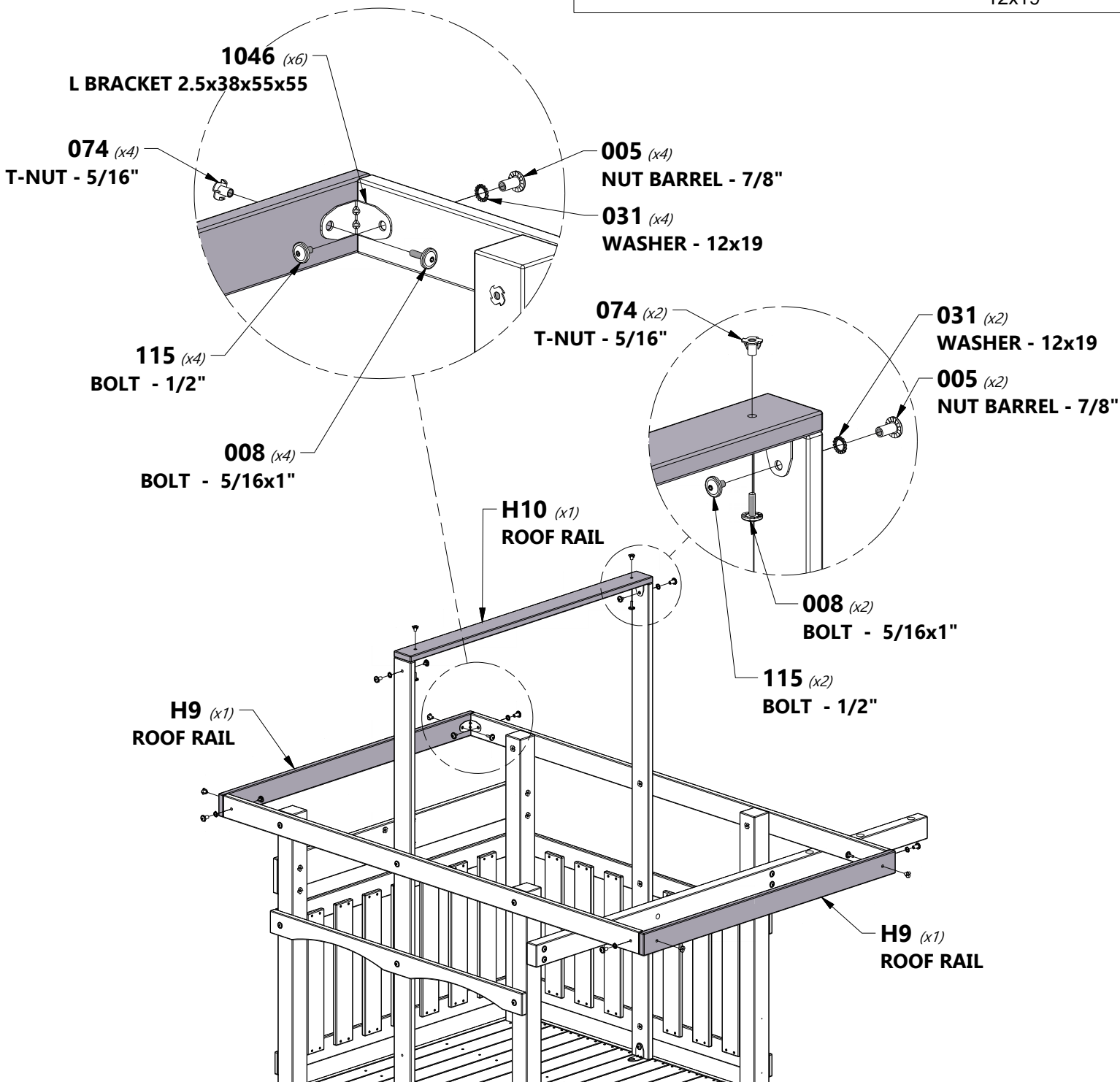

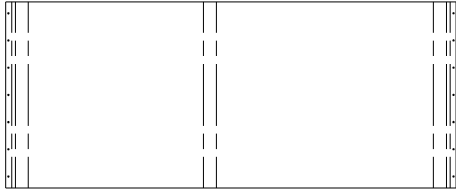
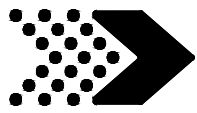

A6P00157 | TARP
(x1)

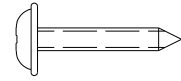

H100070 | SCREW PWH
(x14) | 8x3/4

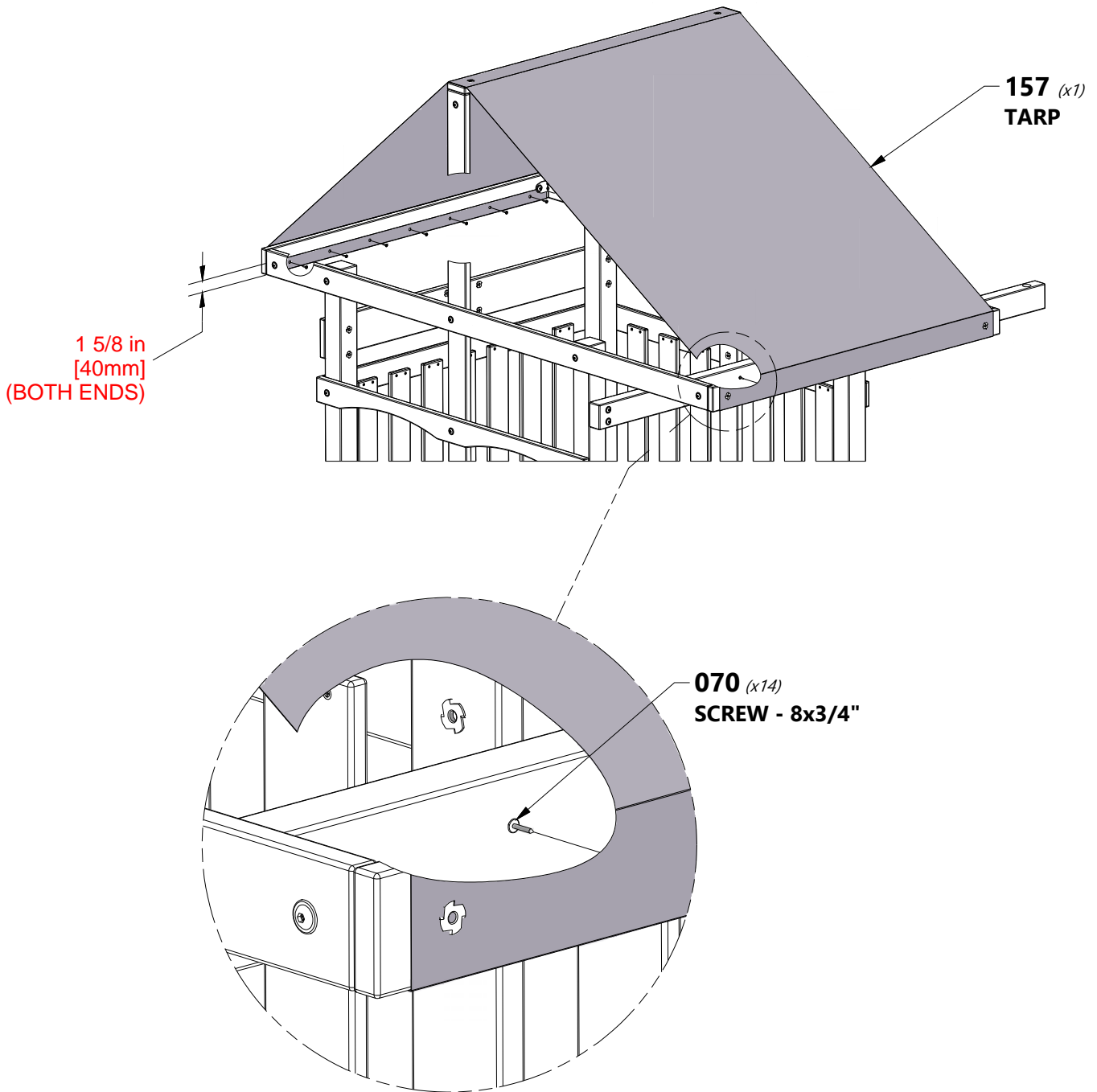

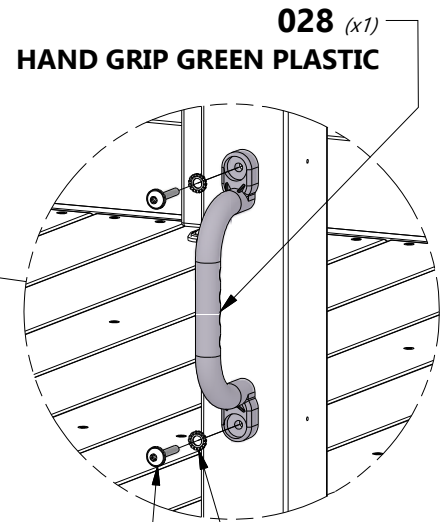
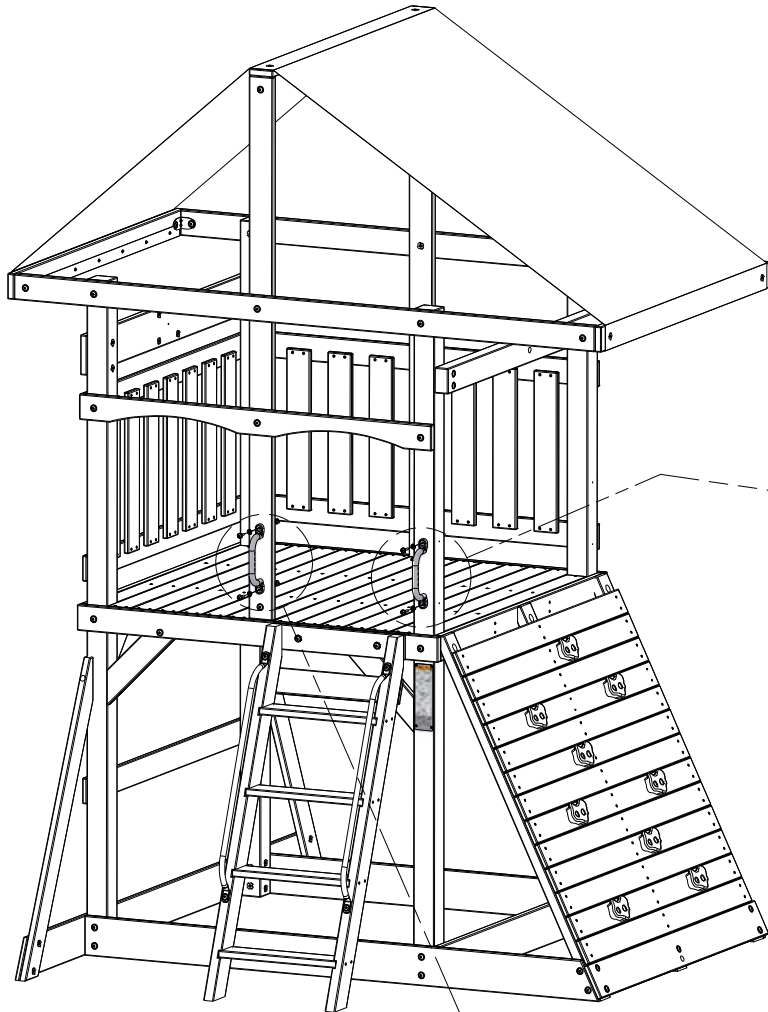
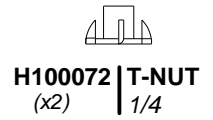
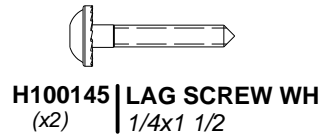
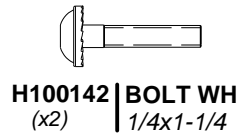
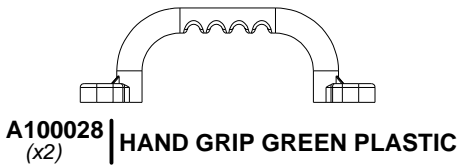
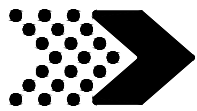

145 (x2)
LAG SCREW - 1 1/2"

138 (x2)
WASHER - 6x15

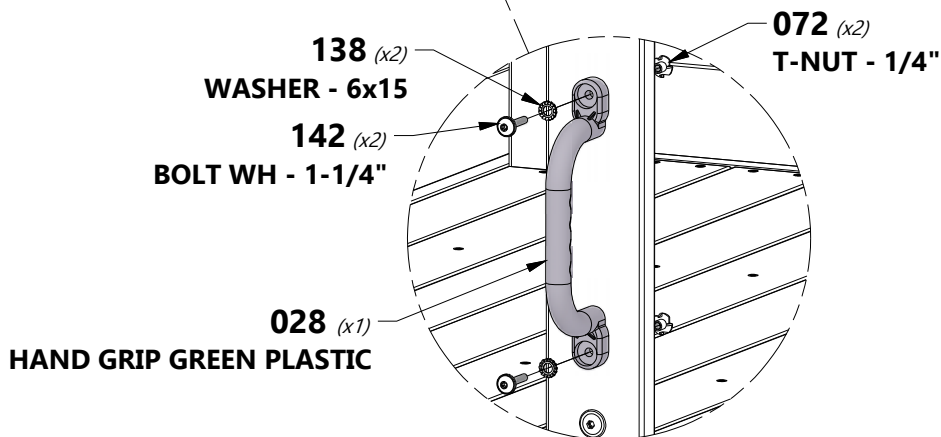

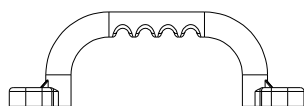

A100028 | **HAND GRIP GREEN PLASTIC**
(x2)

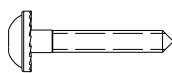

H100145 | **LAG SCREW WH**
(x4) | 1/4x1 1/2



H100138 | **WASHER LOCK**
(x4) | **EXT**
6x15

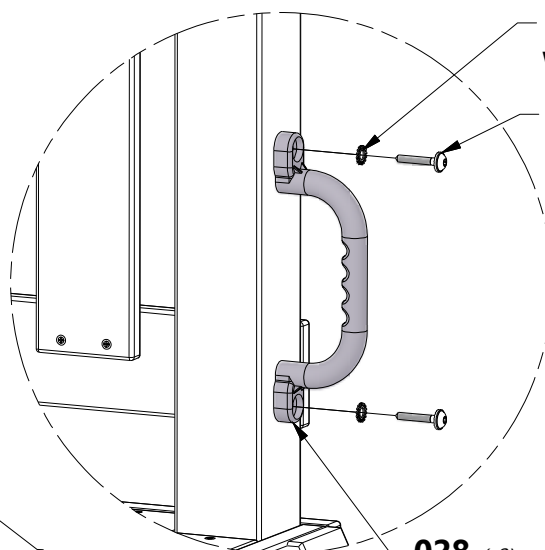
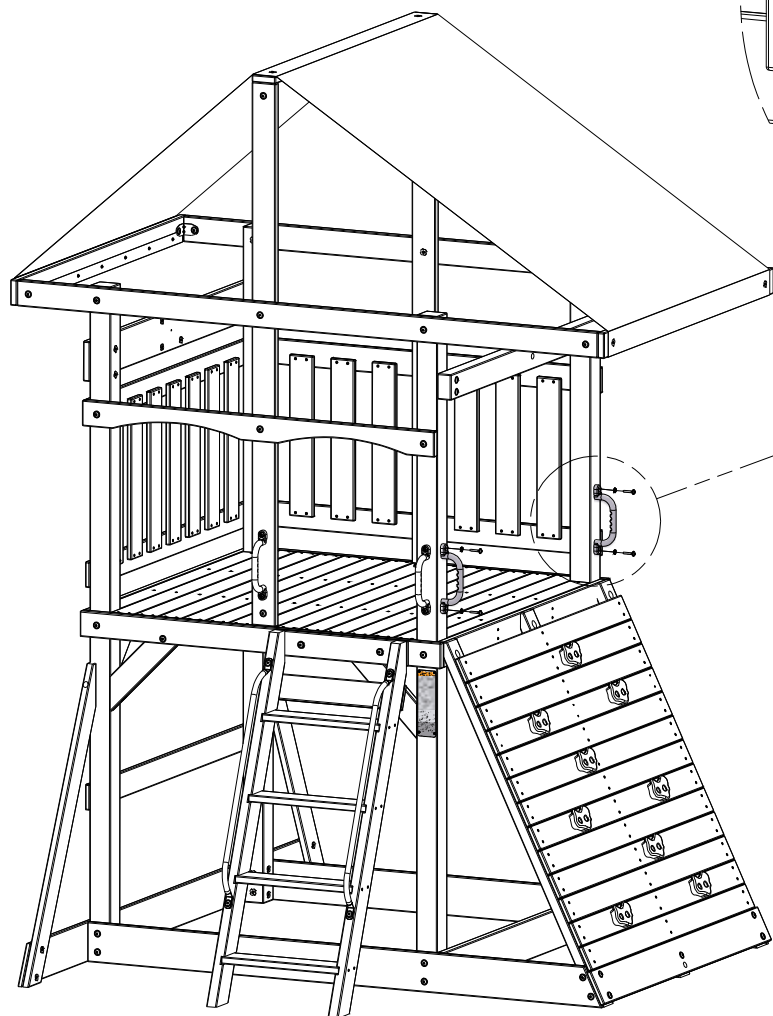

138 (x2)
WASHER - 6x15

145 (x2)
LAG SCREW - 1 1/2"

028 (x2)
HAND GRIP GREEN PLASTIC

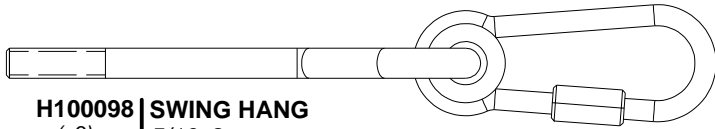
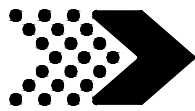

H100098 | SWING HANG
(x3) | 5/16x8

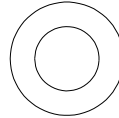

H100103 | WASHER SAFETY
(x3) | 17x30

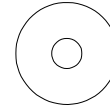

H100105 | WASHER FLAT
(x3) | 8x27



H100110 | NUT LOCK
(x3) | 5/16

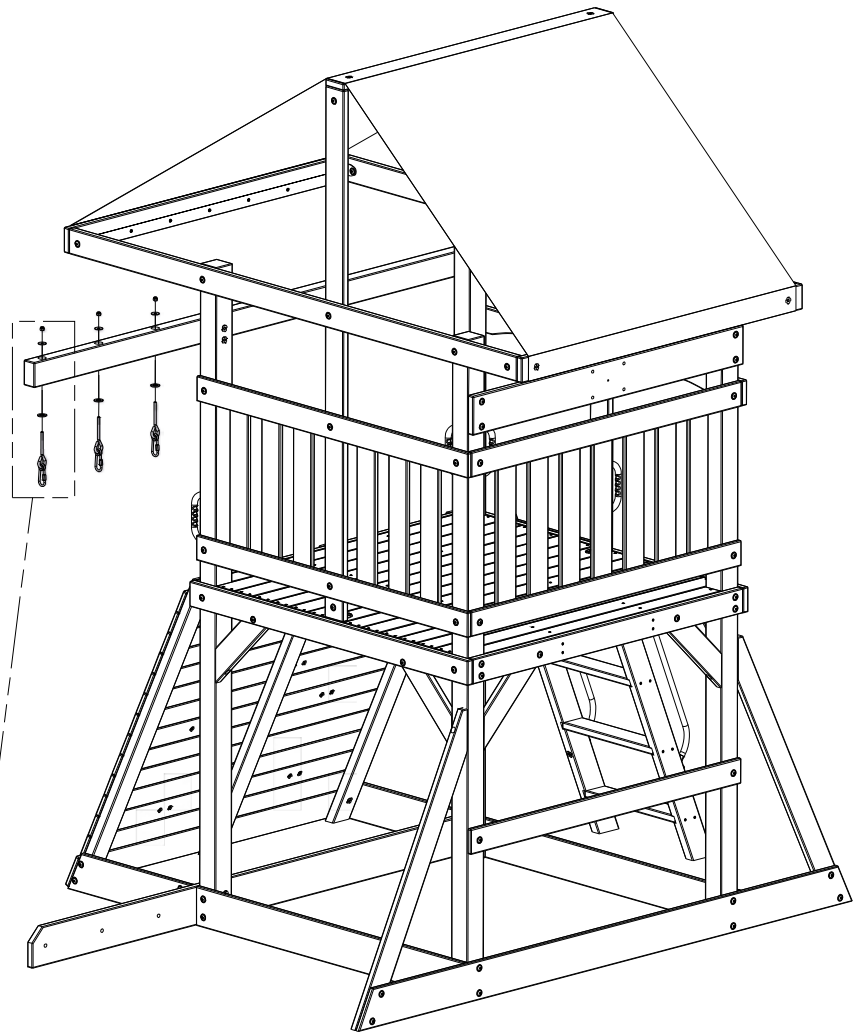

110 (x3)
NUT - 5/16"

105 (x3)
WASHER - 8x27

103 (x3)
WASHER - 17x30

098 (x3)
SWING - HANGER

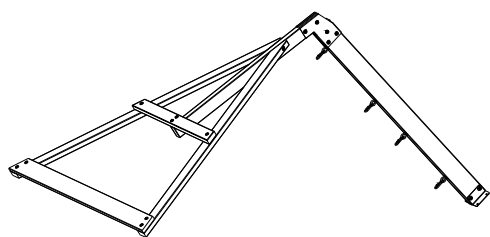

(1) | SWING BEAM ASSEMBLY

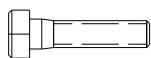

H100042 | BOLT HEX
(x4) | 5/16x1 1/4



H100095 | WASHER SPLIT
(x4) | 5/16

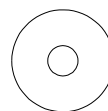

H100105 | WASHER FLAT
(x4) | 8x27

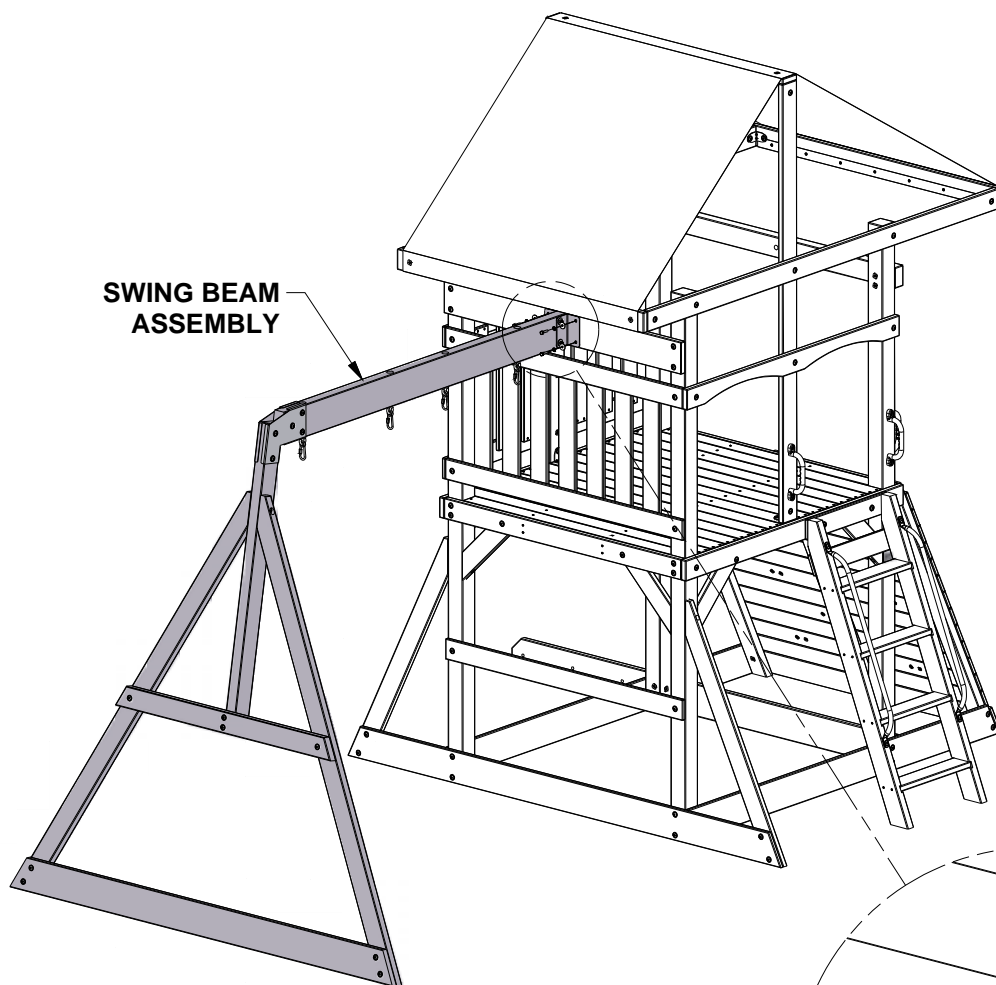

SWING BEAM ASSEMBLY

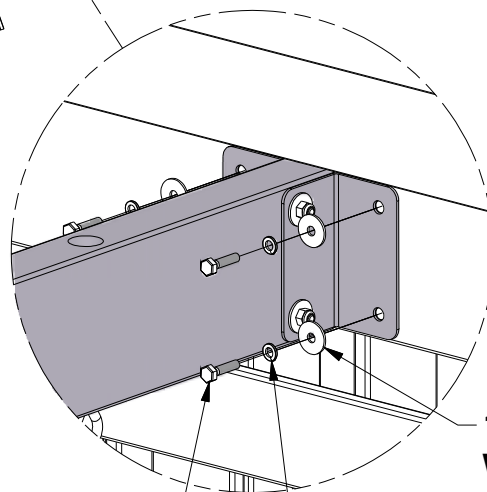

105 (x4)
WASHER - 8x27

042 (x4)
BOLT HEX - 1 1/4"

095 (x4)
WASHER - 5/16"

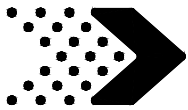

SETUP

WEB SWING

WEB SWING SETUP INSTRUCTIONS:

FOLLOW INSTRUCTIONS BELOW BEFORE USING THE WEB SWING.



H100832 | BOLT PTH BLK (with LOCTITE)
(4) | 1/4x3/4



H100831 | NUT BARREL PTH BLK
(4) | 1/4x3/4



IMPORTANT:
SLIDE ROPE LOOPS OVER TUBE ENDS FIRST!

SLIDE NARROW END OF TUBES INTO LARGER OPENING AFTER SLIDING ROPE LOOPS ONTO TUBES.

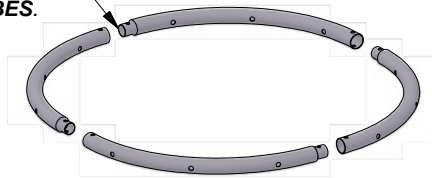

NOTE: ROPE WEBBING NOT SHOWN IN ILLUSTRATION FOR CLARITY.

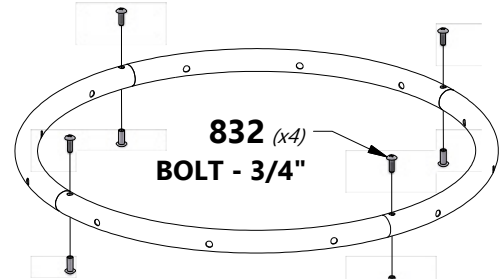

831 (x4)
NUT BARREL - 3/4"



Note: It is important that the web swing hang level.



IMPORTANT
TO ENSURE STRAIGHT SWINGING MOTION, ADJUST BOTH "S" BRACKETS UNTIL WEB SEAT IS LEVEL.

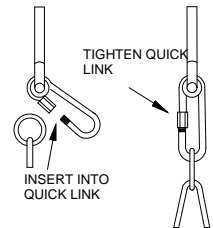
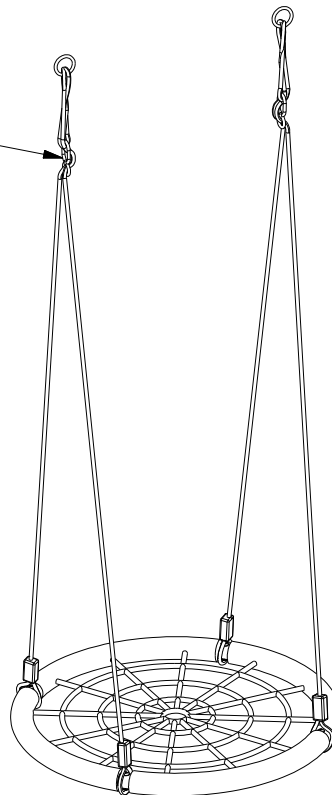

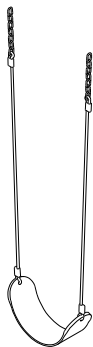

A6P00397 | ROPE-CHAIN GR / SEAT GR 22"
(x1)



A4M01415 | 26" WEB SWING (EU)
(x1)



NOTE:
WHEN HANGING YOUR SWINGS IT IS RECOMMENDED THAT THE BOTTOM OF THE SWING SEAT, WHEN SITTING ON IT, IS LOCATED NO LOWER THAN (35 cm) 13 7/8 INCHES FROM THE GROUND.

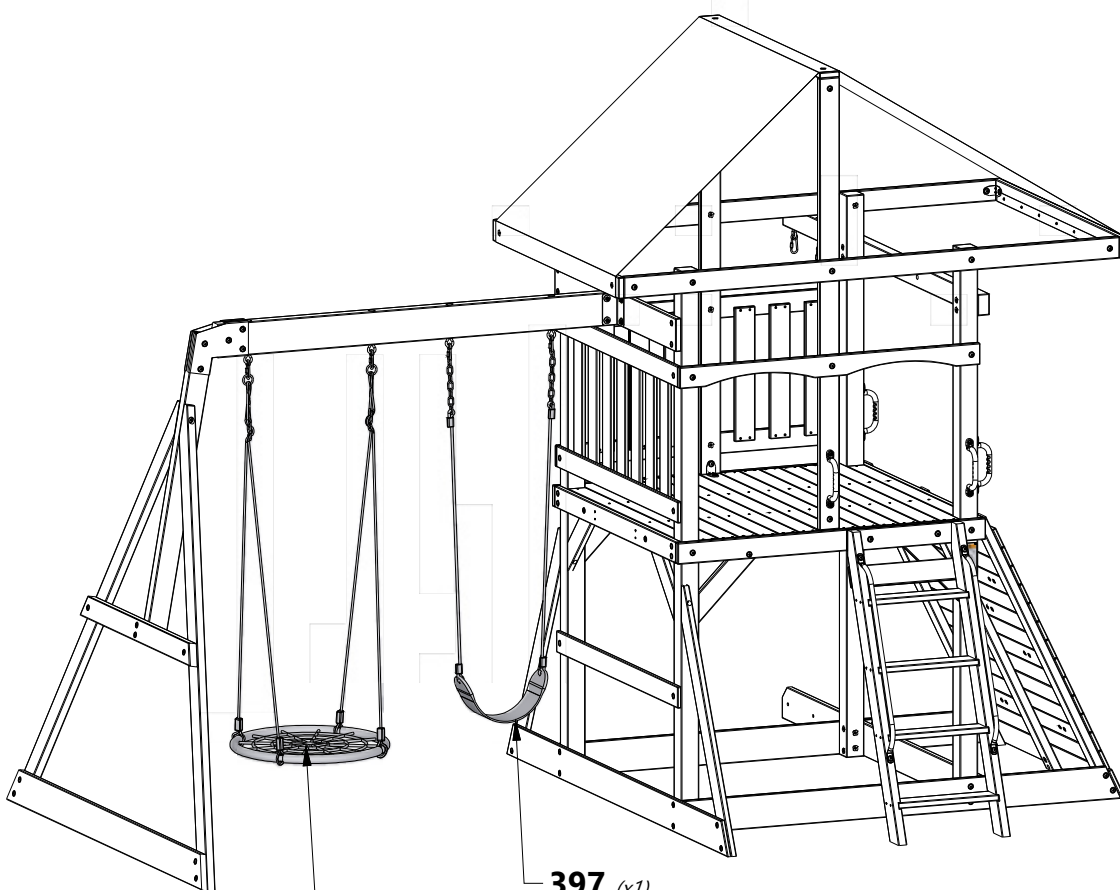
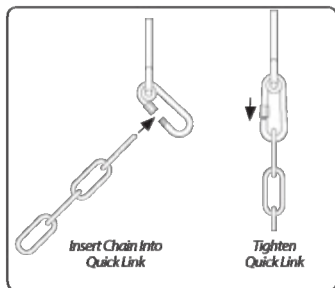

415 *(x1)*
26" WEB SWING
(EU)

397 *(x1)*
SWING SEAT GREEN 22"



A100164 | BYD ID TAG (LARGE) AGES 3-10
(x1)

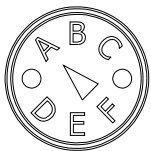

A100314 | "A" REVISION TAG
(x1)

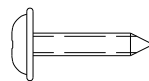

H100128 | SCREW PWH
(x2) | 8x5/8

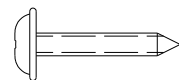

H100070 | SCREW PWH
(x4) | 8x3/4

LOCATE THE REVISION TAG UNDER THE DECK ON THE CENTER JOIST.

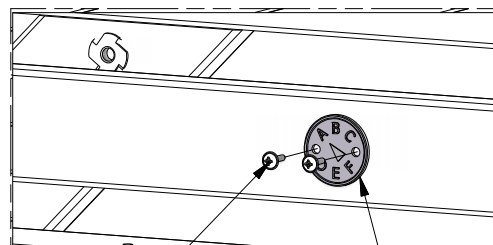

128 (x2)
SCREW - 5/8

314 (x1)
REVISION TAG

164 (x1)
BYD ID TAG (LARGE) AGES 3-10

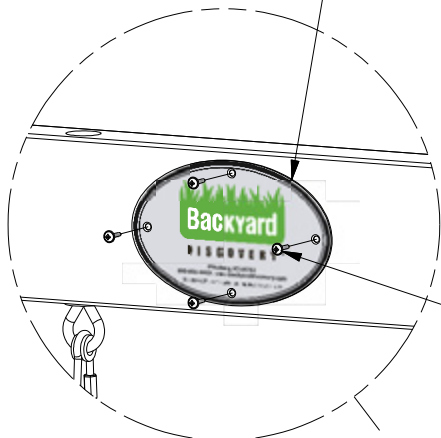

070 (x4)
SCREW - 8x3/4"

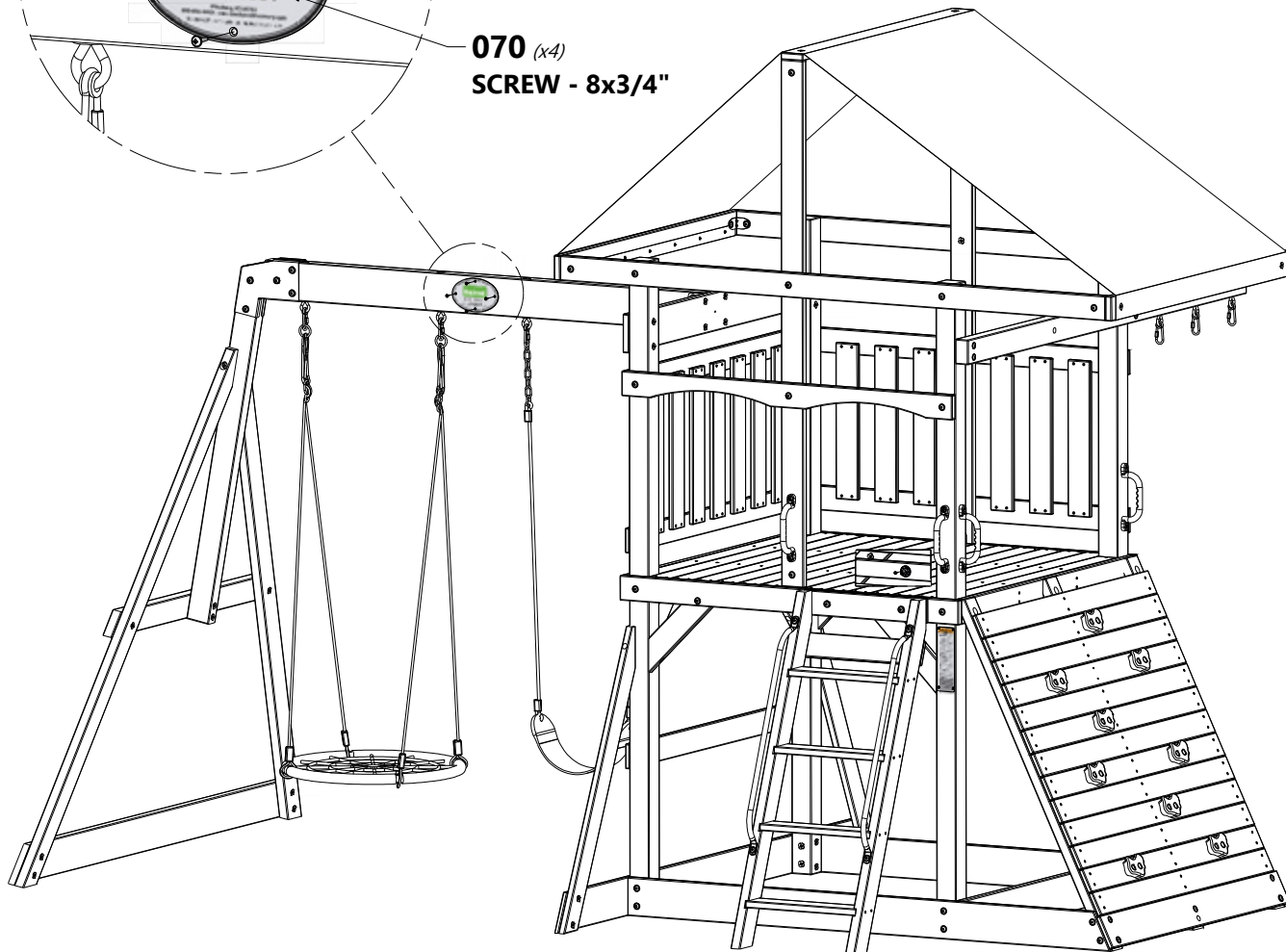

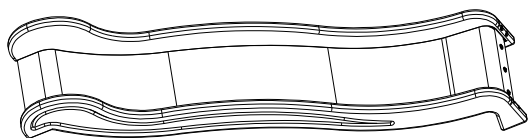

(1) SLIDE ASSEMBLY



H100115 | BOLT WH
(x3) | 5/16x1/2



H100074 | T-NUT
(x3) | 5/16

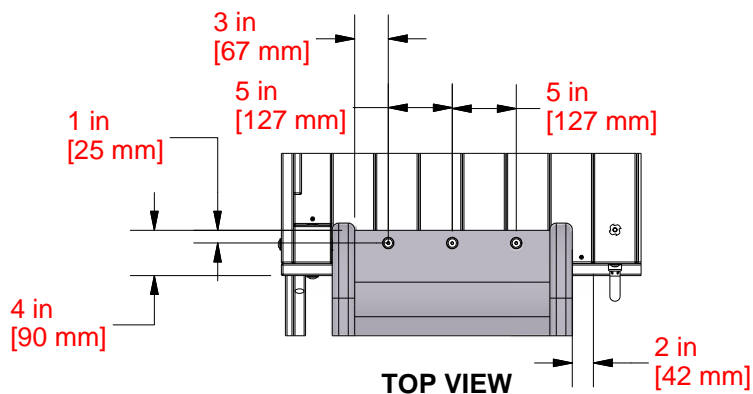
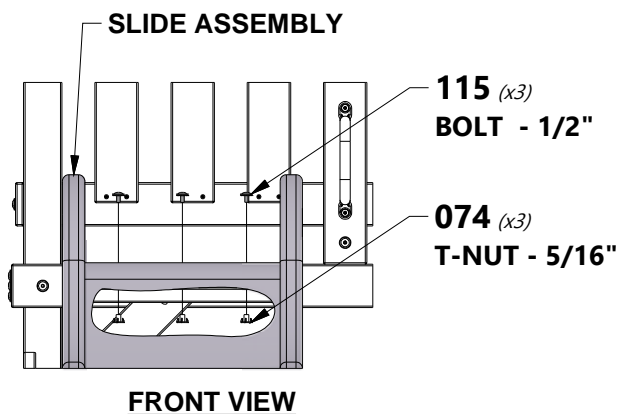

NOTE:
 USING DIMENSIONS SHOWN
 DRILL (3) 3/8" (10 mm) HOLES
 THROUGH SLIDE & FLOOR.
 ATTACHED SLIDE USING
 SUPPLIED HARDWARE.

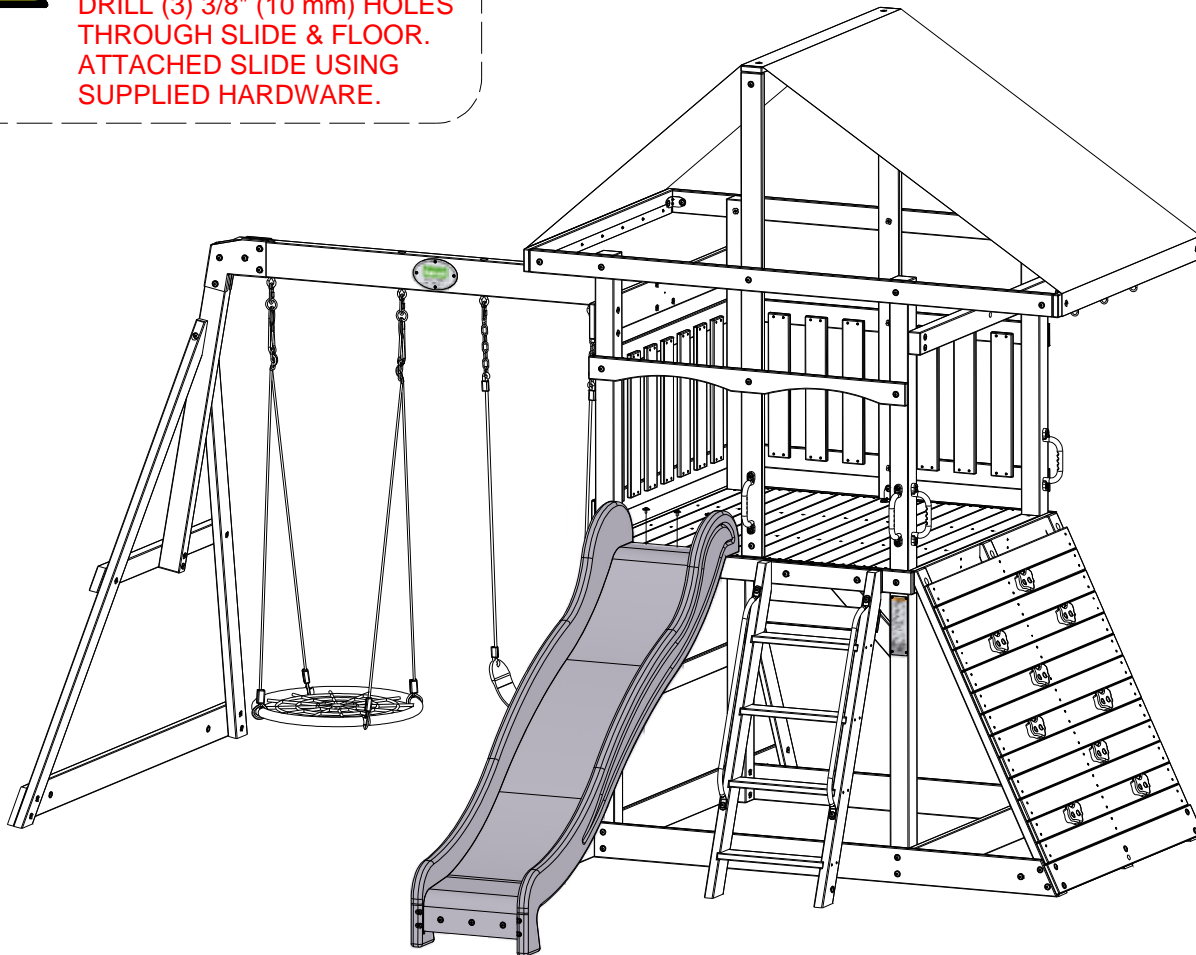

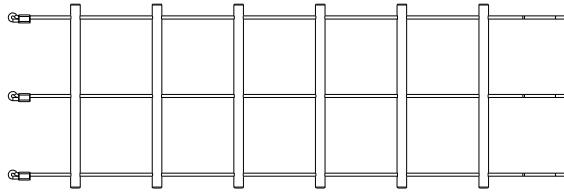
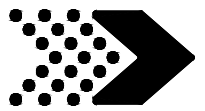

A6P00161 | ROPE LADDER
(x1)

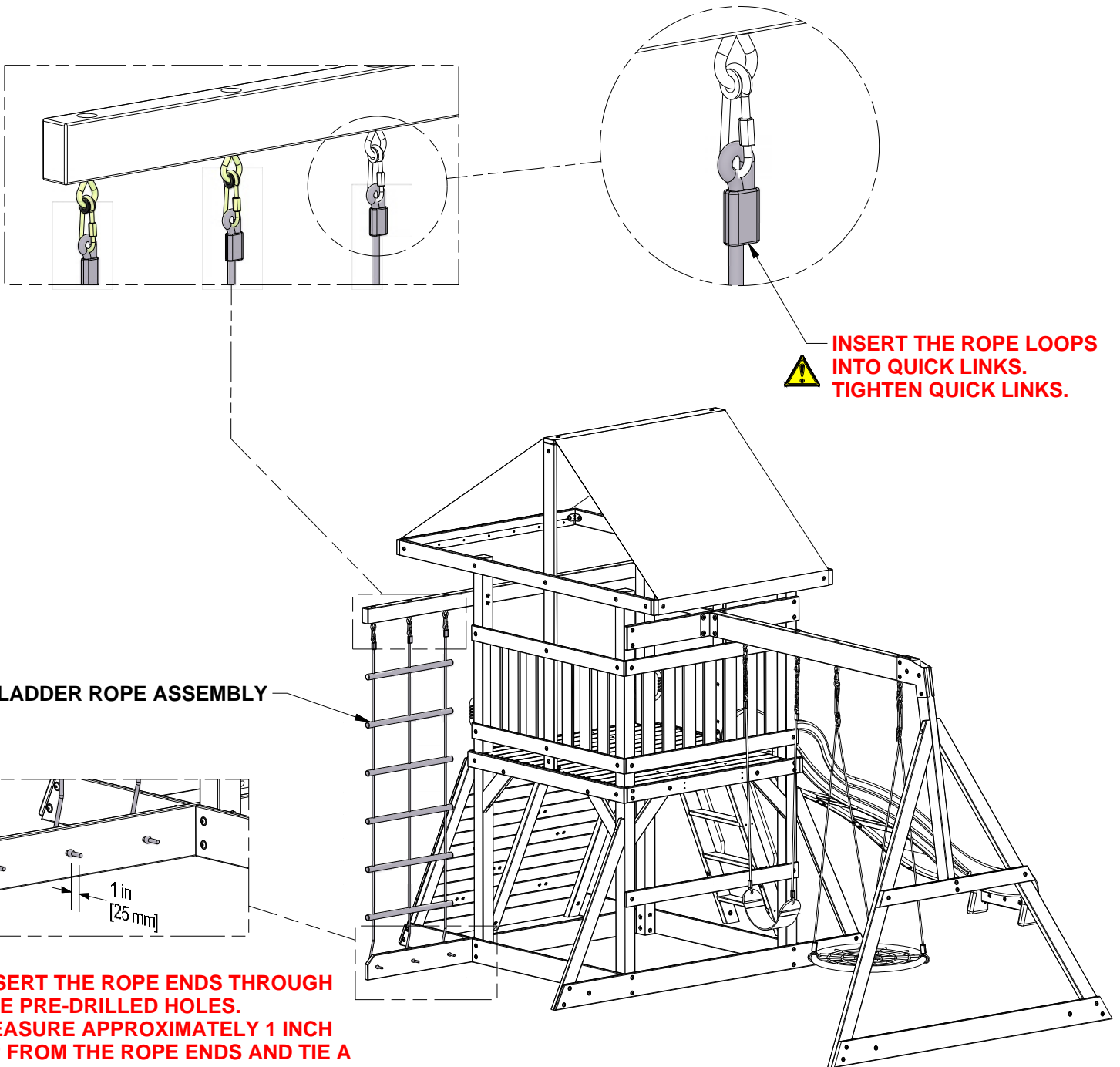

INSERT THE ROPE LOOPS INTO QUICK LINKS. TIGHTEN QUICK LINKS.

LADDER ROPE ASSEMBLY

INSERT THE ROPE ENDS THROUGH THE PRE-DRILLED HOLES. MEASURE APPROXIMATELY 1 INCH UP FROM THE ROPE ENDS AND TIE A KNOT IN EACH ROPE TO SECURE THE ROPE LADDER ASSEMBLY.

1 in
[25 mm]

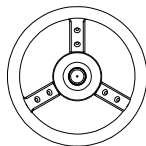

A100107 | STEERING WHEEL
(x1)

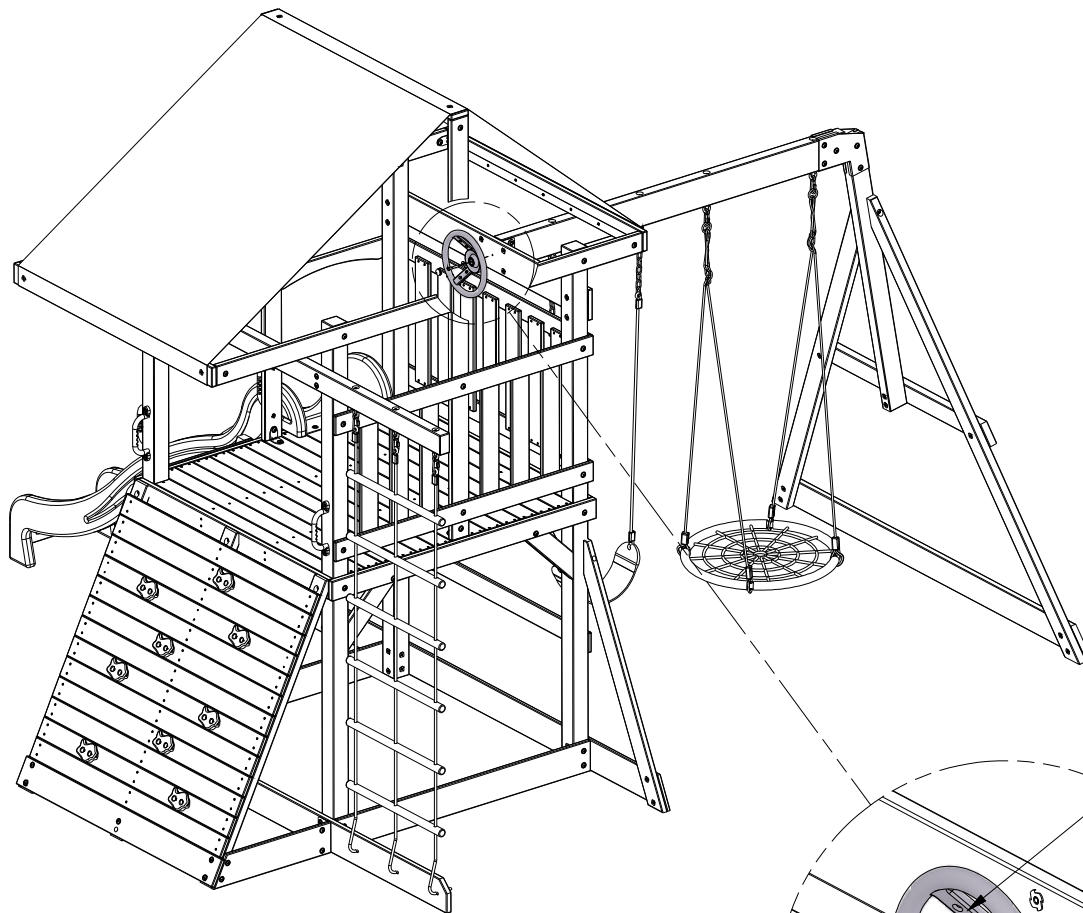

107 (x1)
STEERING WHEEL

(x1) CENTER CAP
(INCLUDED WITH STEERING WHEEL)

(x1) LAG SCREW HEX 5/16x2
(INCLUDED WITH STEERING WHEEL)

(x1) WASHER FLAT OD23xID8.25x2THK
(INCLUDED WITH STEERING WHEEL)

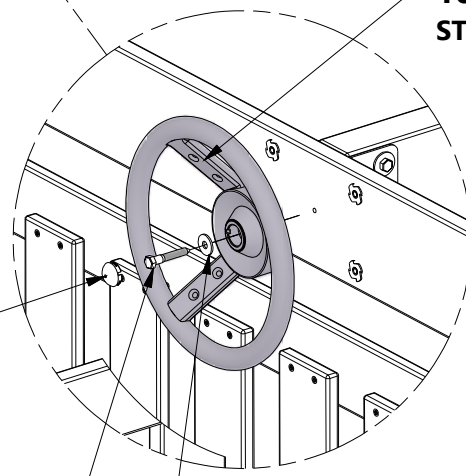

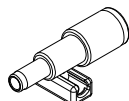

A6P00096 | TELESCOPE
(x1)

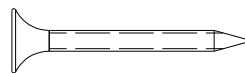

H100087 | SCREW PFH
(x2) | 8x1 1/4"



NOTE:
PILOT DRILL, IN DESIRED LOCATION, USING A
1/8" (3 mm) DRILL BIT.

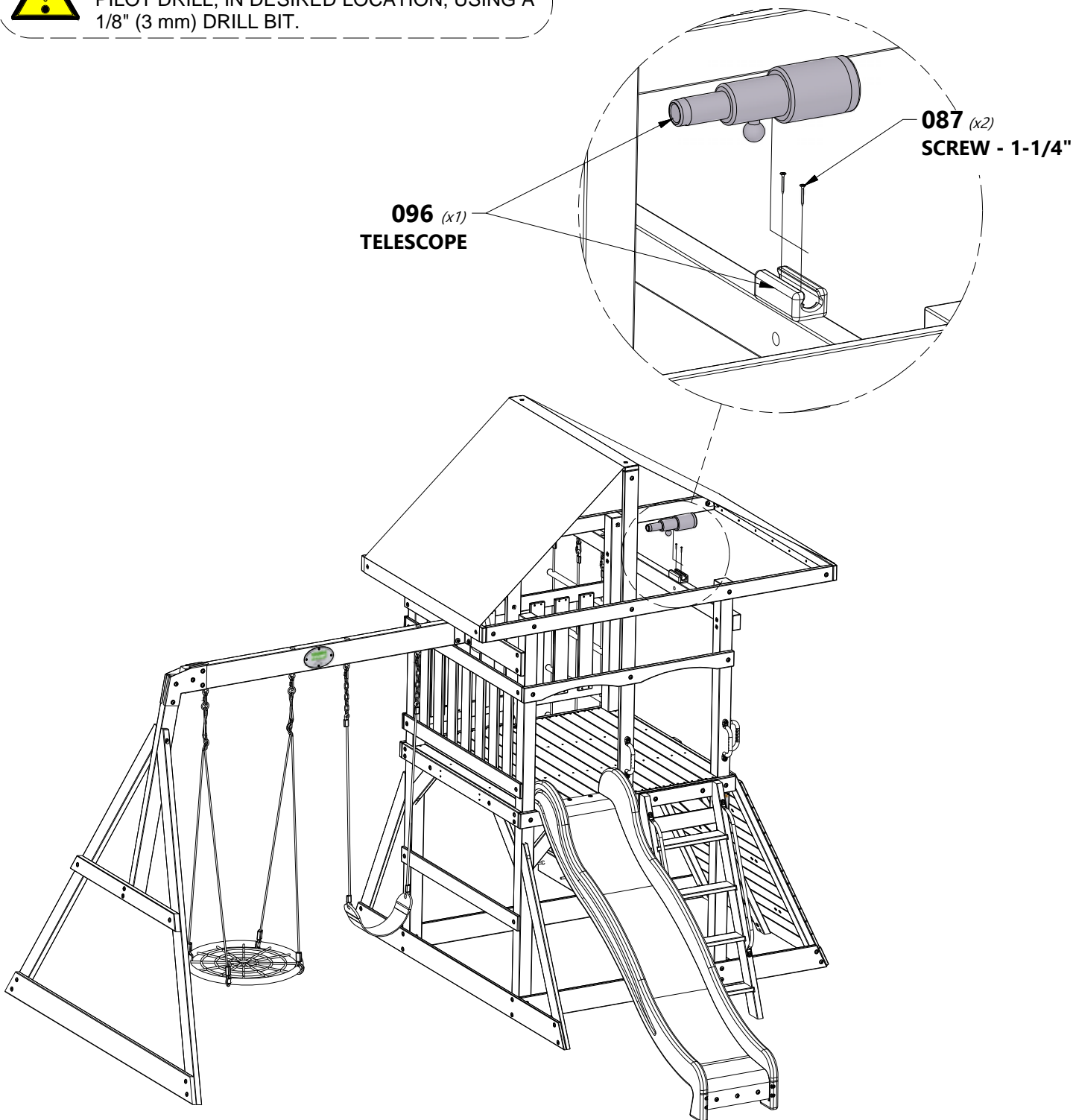



NOTE:
BEFORE ATTACHING ROPE, ADD THREE
KNOTS EVENLY SPACED

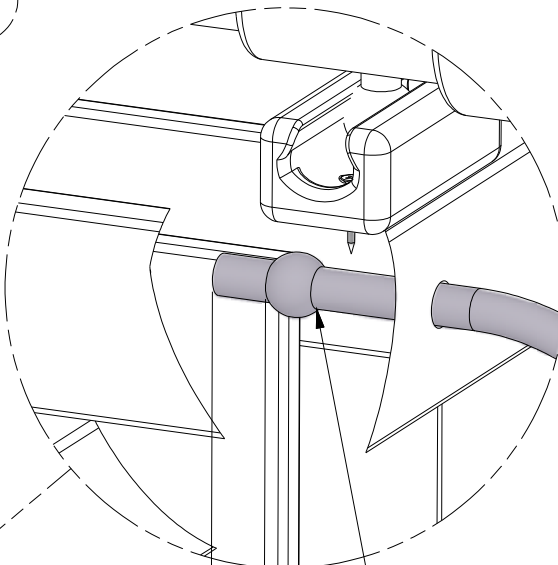

1 in
[25 mm]

**INSERT THE ROPE END THROUGH
THE PRE-DRILLED HOLE.
MEASURE APPROXIMATELY 1 INCH
UP FROM THE ROPE END AND TIE A
KNOT IN THE ROPE TO SECURE.**

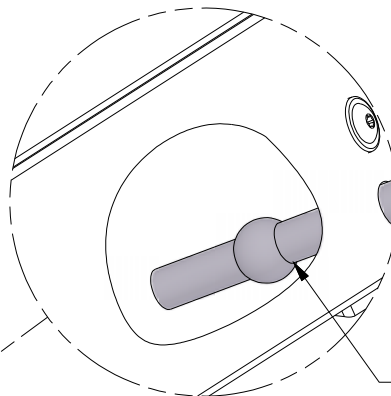
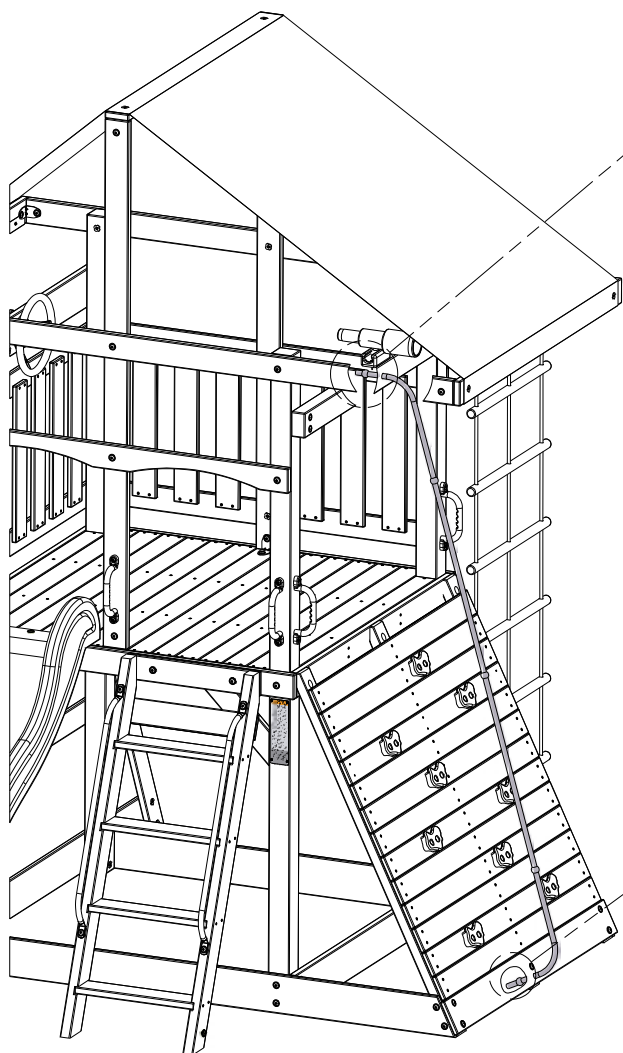

**INSERT THE ROPE END THROUGH
THE PRE-DRILLED HOLE.
PULL TIGHT AND TIE A
KNOT IN THE ROPE TO SECURE.**



A100178 | AUGER GROUND STAKE
(x7)

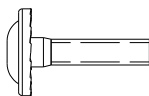

H100009 | BOLT WH
(x1) | 5/16x1 1/4

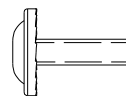

H100008 | BOLT WH
(x2) | 5/16x1

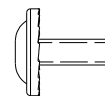

H100222 | BOLT WH
(x4) | 5/16x3/4



H100031 | WASHER LOCK
(7) | EXT
12x19



H100004 | NUT BARREL WH
(x6) | 5/16 x 5/8

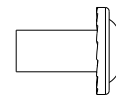

H100005 | NUT BARREL WH
(x1) | 5/16x7/8



NOTE:

TWIST GROUND STAKE INTO THE GROUND WHERE SHOWN. THEN USING GROUND STAKE AS A GUIDE, DRILL A 7/16" (10mm) HOLE FOR HARDWARE.



NOTE:

GROUND STAKE LOCATIONS REPEAT ON OPPOSITE SIDE.

